

# **Settop-Box**

## **Service Manual**

**Model : Srt4125**

***STRONG***

# CONTENTS INDEX

<b>1. Block Diagram.....</b>	<b>3</b>	<b>page</b>
<b>2. Features.....</b>	<b>4</b>	<b>page</b>
<b>3. Technical Specification.....</b>	<b>5~8</b>	<b>page</b>
<b>4. Trouble Shooting.....</b>	<b>9~17</b>	<b>page</b>
<b>5. Bill of Materials List.....</b>	<b>18~24</b>	<b>page</b>
<b>6. Circuit Drawing.....</b>	<b>25~37</b>	<b>page</b>
<b>6-1. Main / Front PCB Board</b>		
<b>6-2. SMPS PCB Board</b>		
<b>7. Firmware, OTA Software Downloading Method.....</b>	<b>38~39</b>	<b>page</b>

# 1. BLOCK DIAGRAM

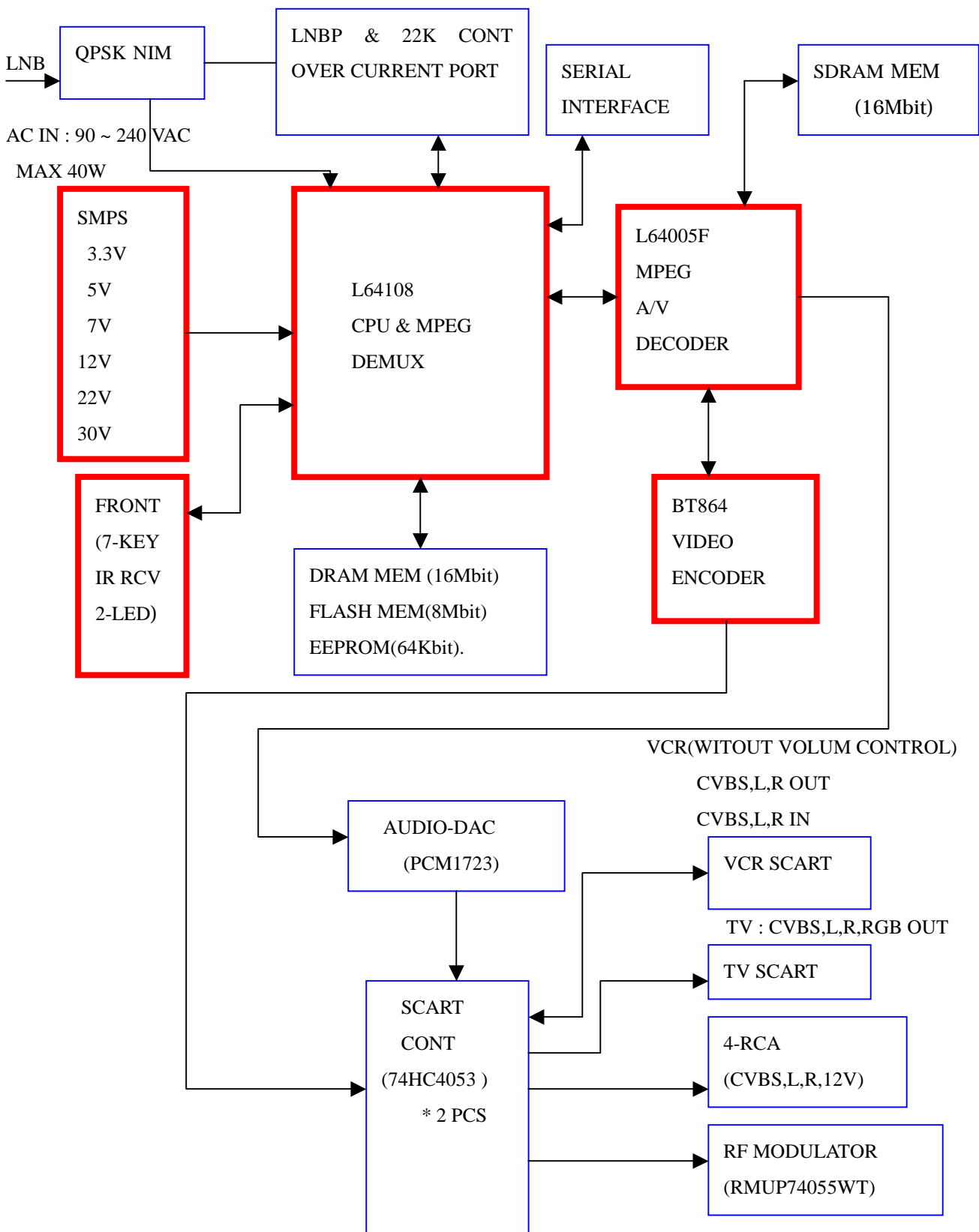

## 2. Features

- Easy Graphic MENU Interface
- RS232C Port for Updating Control Software and Additional Service
- Supports DiSEqC1.0,1.2
- 2-SCART(TV,VCR) Connectors & RCA(CVBS,L,R)
- Multi-language Function(Menu, Audio)
- Last Channel Memory
- OSD: Transparency & Blending, 16 Colors
- Front Panel Buttons(S/B On & Off) & IR Remote Controller User Interface
- Editing Functions(TV or Radio Channel, Channel Name, PID, Transponder Name)
- EPG for On Screen Channel Information
- Channels Memory for Multi-satellite(up to 64)
- 3 Operation Modes(Digital TV, Digital Radio, Favorite)
- Receives QPSK Satellite Broadcasting RF Signal and Decodes the Digitally Encoded Signal
- Digital Tuner with Loop-through
- SCPC/MCPC Receivable from C/KU-band Satellite
- Wide Symbol Rate 2~45 Mbps & 950~2150 MHz input Frequency
- MPEG-2 Main Profile at Main Level
- Teletext Supported
- 2100 Channels Memory(Digital 2000, Favorite 100)
- PLL RF Modulator UHF 21~69 with PAL BG/I/DK

### 3. TECHNICAL SPECIFICATIONS

Transmission Standards : DVB, MPEG2

#### 1. TUNER & DEMODULATOR

Input Frequency Range	950MHz to 2150MHz
RF input Signal Level	-25 ~ -65 dBm
RF impedance	75 ohms
IF Bandwidth	55MHz / 8MHz(under 5Msps)
LNB Power	13.5 / 18.5Vdc +/- 5%,0.5Amax,1.2Apeak overload protected
LNB tone switch	22KHz +/- 2KHz, 0.6Vpp +/- 0.2V
DiSEqC	Version1.0,1.2 Tone burst A/B
Demodulation	QPSK
Symbol Rate	2 ~ 45 Msps / SCPC,MCPC

#### 2. MPEG

Transport Stream	MPEG-2 TS Specification(ISO/IEC 13818)
Input Rate	Max. 15Mbit/s
VIDEO	MPEG-2 <a href="#">MP@ML</a>
AUDIO	MPEG-1/2 Audio layer 1,2
Aspect Ratio	4:3, 16:9
Video Resolution	720 × 576(PAL), 720 × 480(NTSC)
Audio mode	Stereo, Dual channel, Joint stereo, Mono
Audio Sampling Frequency	32/44.1/48KHz

#### 3. Connector

LNB IF input	1 × F Type
LNB IF loop through output	1 × F Type
TV SCART	RGB, CVBS, L, R out
AUX SCART	CVBS, L, R out RGB, CVBS, L, R in
RAC JACK	CVBS Audio L, R 0/12Vdc out
Serial Port	RS232C D-sub maleType

#### 4. MEMORY

FLASH MEMORY	1 Mbytes
DRAM	2 Mbytes
SDRAM	2 Mbytes
EEPROM	16Kbit

#### 5. RF-Modulator

RF – Connect	75 W IEC169-2, Male/Female
Frequency	470 MHz to 860 MHz
Output Channel	CH 21 –69 for the Modulator
TV Standard	PAL B/G/I/D/K selectable by Menu setting

#### 6. POWER Supply

Supply Voltage	85Vac ~ 260Vac(SMPS)
Power Consumption	Max 30W
Physical Size	280 m/m
Weight	Approx. 2.5kg
Operating Temperature	0 °C ~ 40 °C
Storage Temperature	-40 °C ~ 65 °C

#### SCART –socket

PIN No.	TV	AUX
1	Audio out Right	Audio out Right
2	-	Audio in Right
3	Audio out Left	Audio out Left
4	Audio ground	Audio ground
5	Blue ground	Blue ground
6	-	Audio in Left-
7	BLUE out	BLUE in
8	Function control out	Function control in
9	Green ground	Green ground
10	-	-
11	GREEN out	GREEN in
12	-	-
13	Red ground	Red ground

14	Fast blanking ground	Fast blanking ground
15	RED out	RED in
16	Fast blanking out	Fast blanking in
17	Cvbs ground	Cvbs ground
18	Cvbs ground	Cvbs ground
19	CVBS out	CVBS out
20	-	CVBS in
21	Ground	Ground

Serial(RS-232) Connector

PIN No.	Signal Name
1	-
2	RXD(Receive Data)
3	TXD(Transmit Data)
4	-
5	Ground
6	-
7	-
8	-
9	-

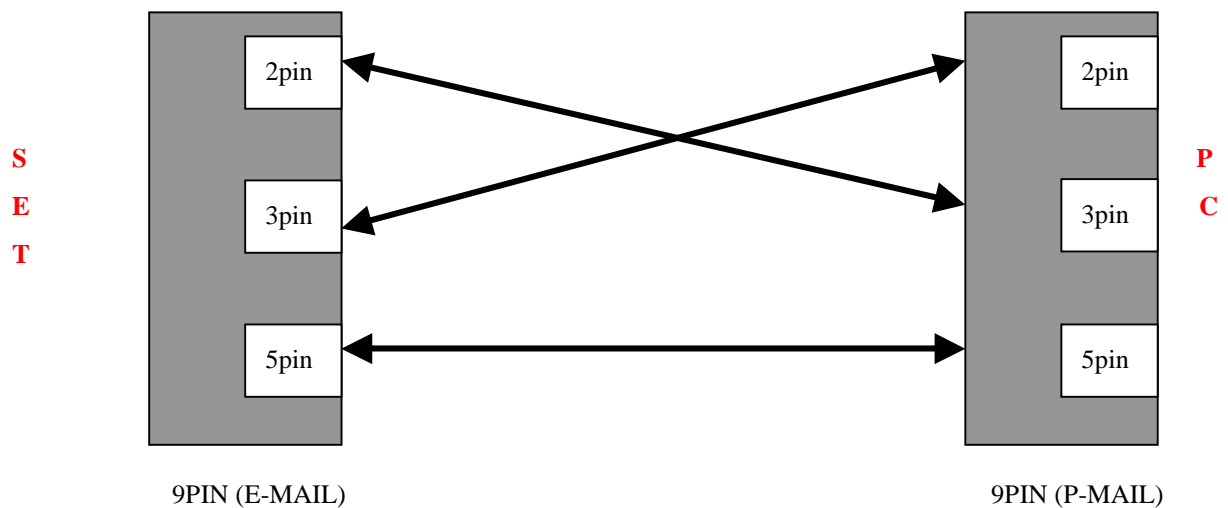

REAR Panel(BACK View)

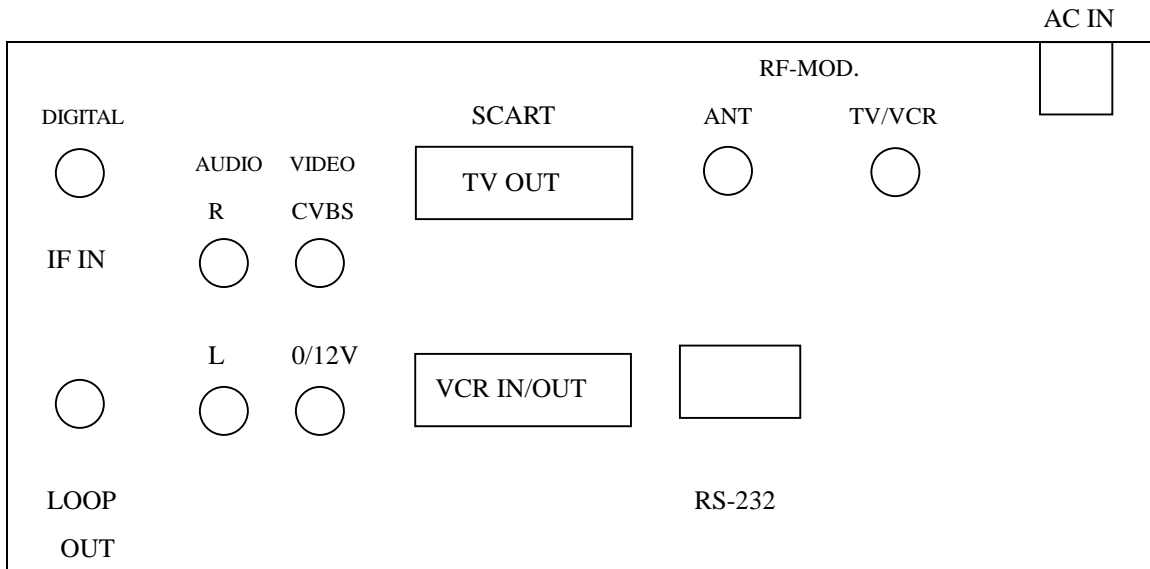

## 4. Trouble Shooting

### ◆ 4-1. Appearance (Exterior) Test

Check the condition of install, joining of connectors, break or bend of PCB, cold-soldering or Short of components and problem of part ,etc.

### ◆ 4-2. Power Test

5V Checking to BD(901,902,903)

3.3V Checking to BD(904,905)

30V Checking to BD906

23V Checking to BD907,908

12V Checking to BD909

7V Checking to BD910

### ◆ 4-3. System Test

Check whether CPU of L64108 , flash-Rom of TE28F800C3-T working

Check Message Display , Execute Hyper Terminal in PC

\* Condition of Hyper Terminal configuraion

Baud rate(115,200 bps)

Data bit(8bit)

Parity bit : none

Stop bit : 1

Control : none

### - ERROR CODE LIST -

E001 : Tunner Error

E002 : EEPROM Error

E003 : RF Error

E004 : BT864 Error

E005 : L64005 Error

E006 : DRAM Error

4-3-1. L64018 Clock uses VCXO as system clock(27Mhz) and L64108 output clock(54Mhz)

4-3-2. Flash-Rom of Start Control Signal uses reset, chip-Select

### ◆ 4-4. MPEG and Audio Video Test

check the whole process from MPEG Decoder(L64005) and Video Encoder(BT864) of R,G,B,CVBS

Also Check the Audio signal( U502(PCM1723 or (U501)AK4323)

Output port(SCART,Phone Jack,RF-Modurator)

4-4-1. L64005(MPEG-2 Audio/Video Decoder)

4-4-2. Video Filter from Bt864A (Digital Video Encoder)

4-4-3. Audio DAC(U501(AK4363) & U502(PCM1723))

### ◆ 4-5. Channel Test

4-5-1. when "NO SIGNAL " Message display.

1. U106(KA317 Regrator)-> pin3 at 21V ~24V check

R114 by 13(Vert) or 18(Horz) Voltage check

2. I2C Control signal

◆ 4-5-2. 22Khz Control through , TS-Data and Data Error control signal

◆ 4-3-1. L64018 Clock uses VCXO as system clock(27Mhz) and L64108 output clock(54Mhz)

27Mhz -->  
Check point : U201 (7pin)

54Mhz -->  
Check point : U201 (20pin)

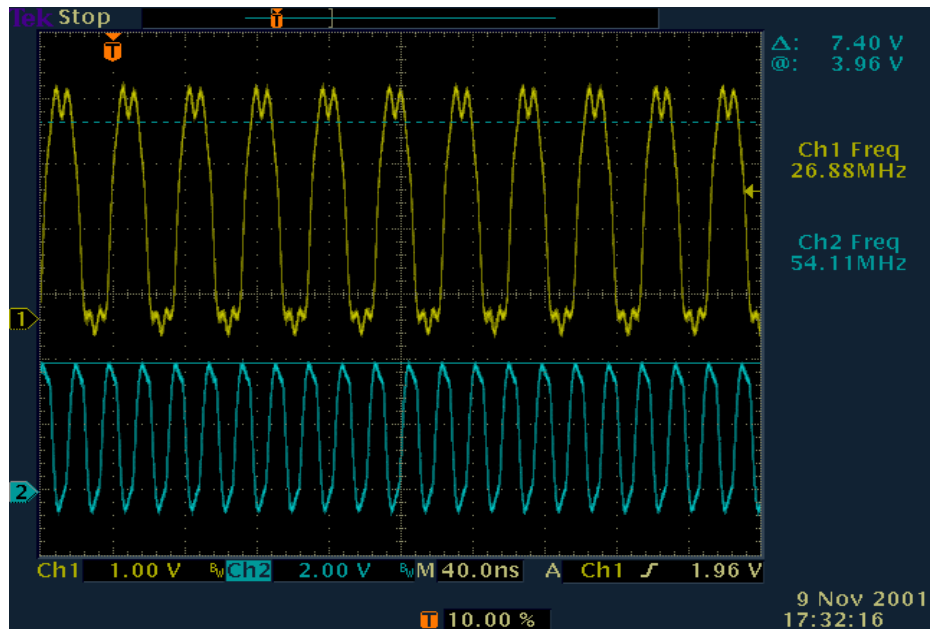

ST --->  
Check point : U206 (4pin)

(LOW active) reset --->  
Check point : U206(1pin) & U202(12pin) & U201(145pin).

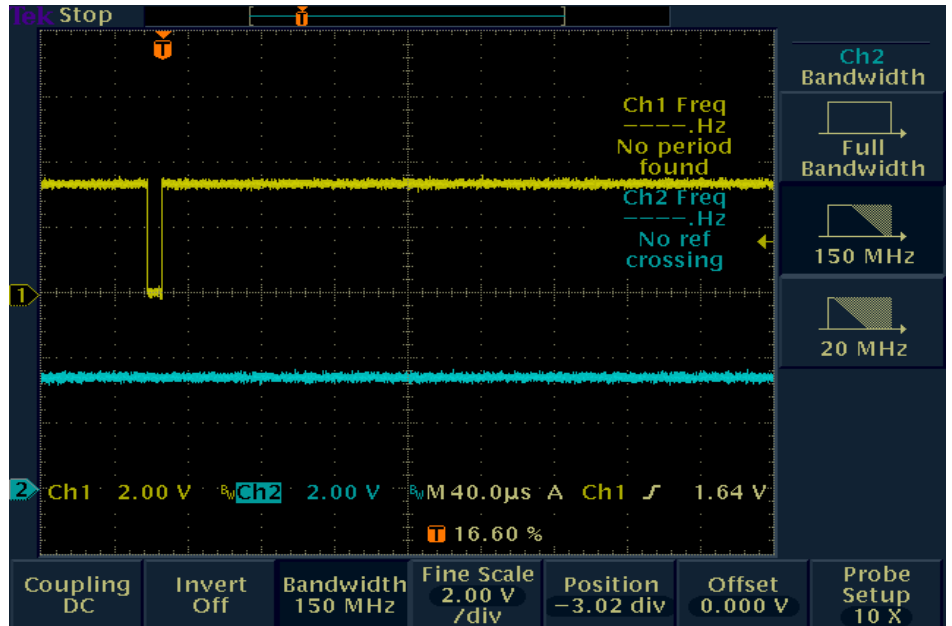

◆ **Failure Causes and Solution.**

If the 27Mhz is acting unstably . VCXO with U105 or L64108 is damaged. Replacement of part is required. Because 54Mhz clock and 27Mhz clock is not generated from inside of the chip , soldering or Chip is considered as a cause.

◆ 4-3-2. Flash-Rom of Start Control Signal uses reset, chip-Select

RESET --→  
Check Point : U202(12pin)

CE --→  
Check Pint : U202(26 pin)

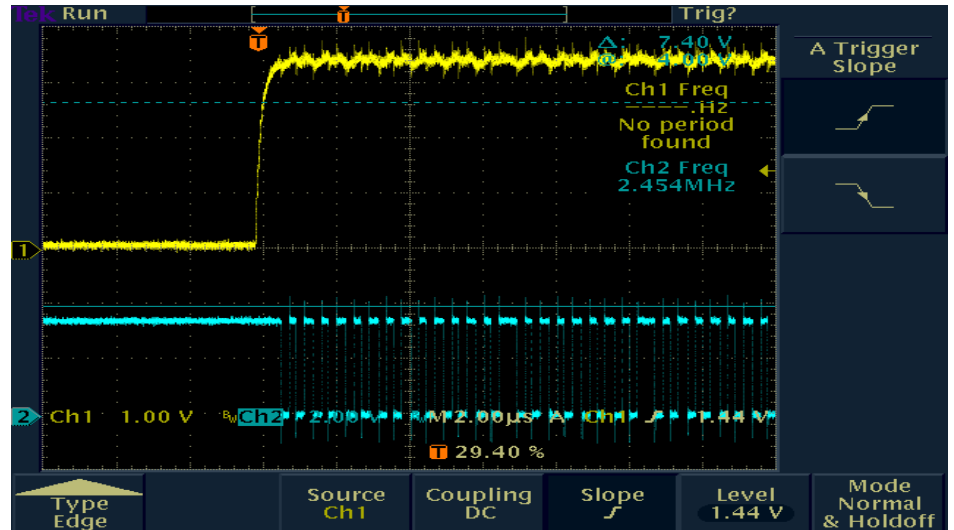

◆ **Failure Causes and Solution.**

If the flash-Rom(U202) not operation. , must be Checking chip-select pin from L64108. Replacement of part is required. Because Reset and Chip-Select signal is not Booting.

Also , Checking soldering or Chip is consider flash-rom and CPU. Where are replace of component Part, and Check the insertion of part

◆ 4-4-1. L64005(MPEG-2 Audio/Video Decoder)

27Mhz(SCLKI, SYSCLK)-->  
 Check pontU301 (82pin,87pin)

PD(0,1,2,3,4,5,6,7) -->  
 Check Point : RA301,RA302

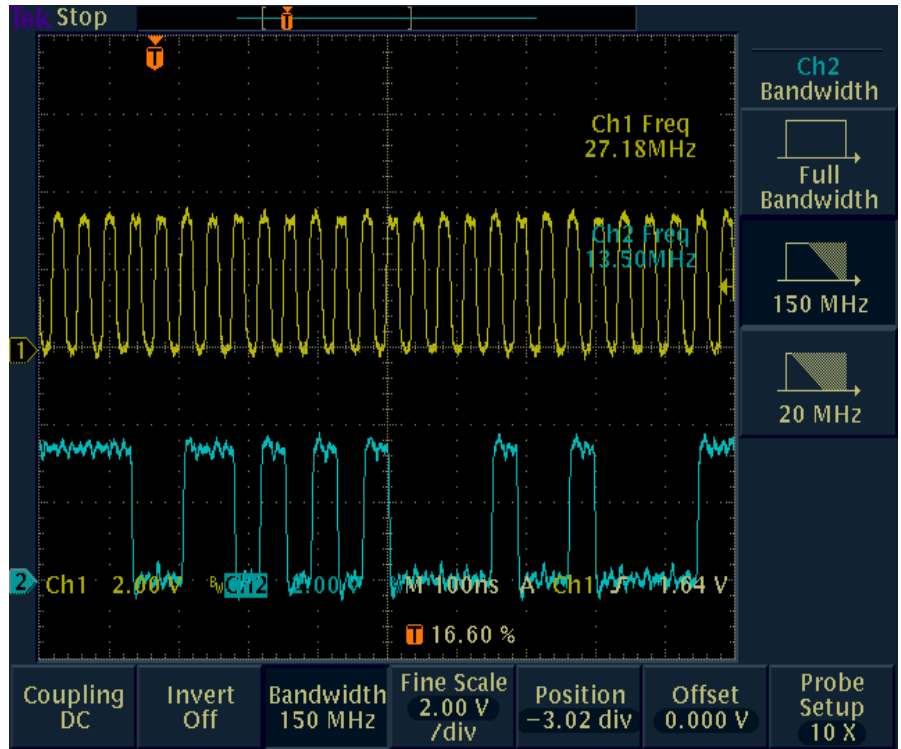

005\_ACLK -->  
 Check Point: RA303(4pin)

BICK -->  
 Check Point : RA303 (1pin)

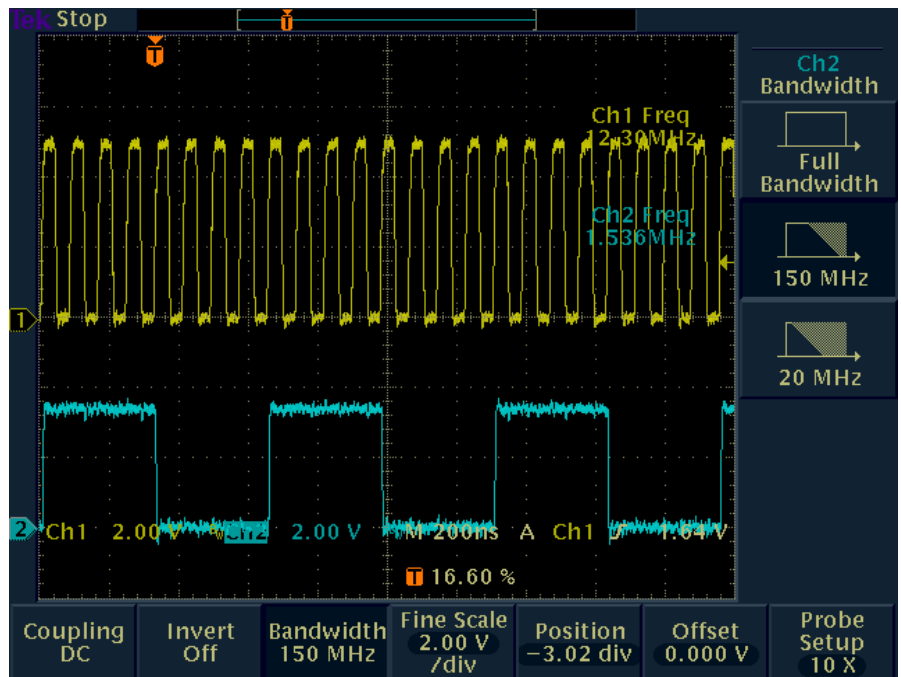

◆ **Failure Causes and Solution.**

If the 27Mhz is acting unstably . VCXO, U105(74HC04) is damaged. Replacement of part is required.

Because 27Mhz clock is not generated from inside of the chip , soldering or Chip is considered as a cause. Where are

replace of component Part, Check the insertion of part

◆4-4-2. Video Filter from Bt864A (Digital Video Encoder)

CVBS -->  
Check Point : L402

(LOW active) RESET -->  
Check Point : U401(47pin)

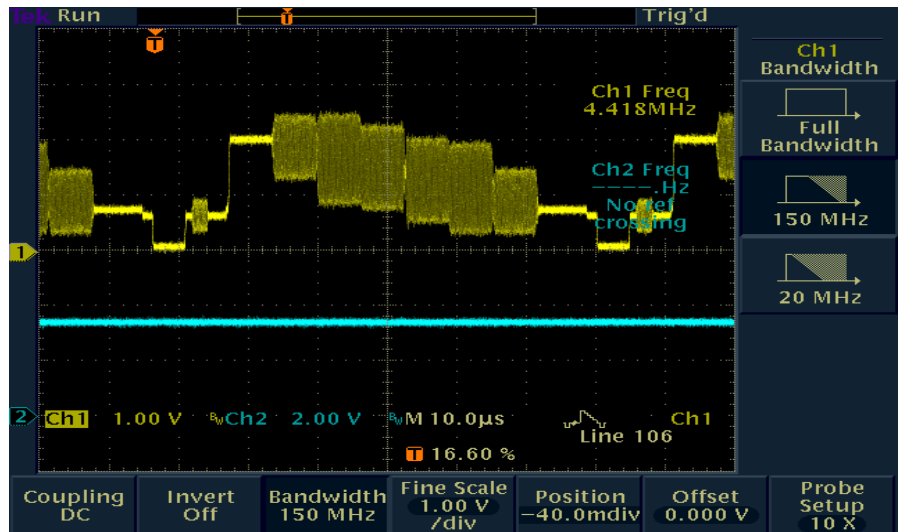

RED -->  
Check Point : L403

GREEN -->  
Check Point : L404

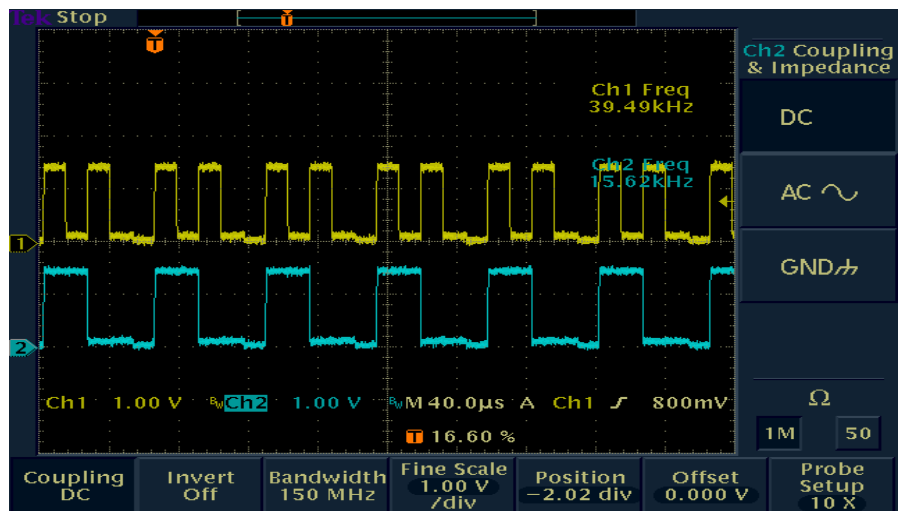

BLUE -->  
Check Point : L405

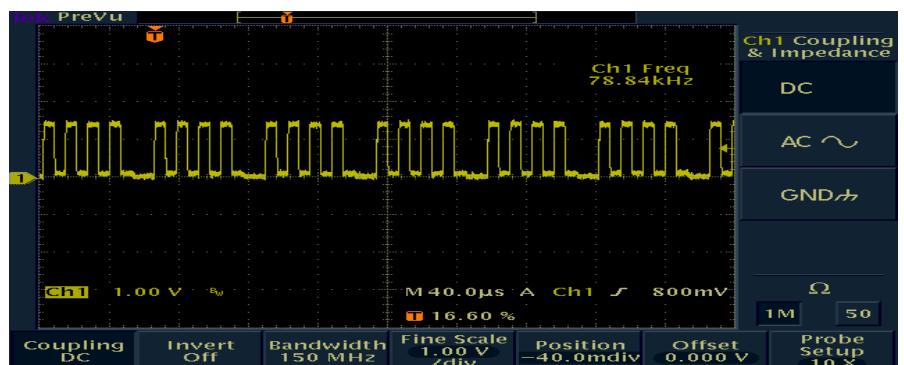

◆ Failure Causes and Solution.

If the Color signal is not operation. Should be Checking 43pin(SYSCCLK) 27Mhz Of U401 and VCC(3.3V) if you have checking, If No problem. Check the install chip-position and short of solder, cold solder, etc.

Where are replace of component Part, Check the insertion of part

4-4-3. Audio DAC(U501(AK4363) & U502(PCM1723))

SYSCLK -->  
 Check Point : U502 (1pin)  
 U501(5pin)  
 005\_ACLK -->  
 Check Pont : U502 (2pin)  
 U501 (1pin)

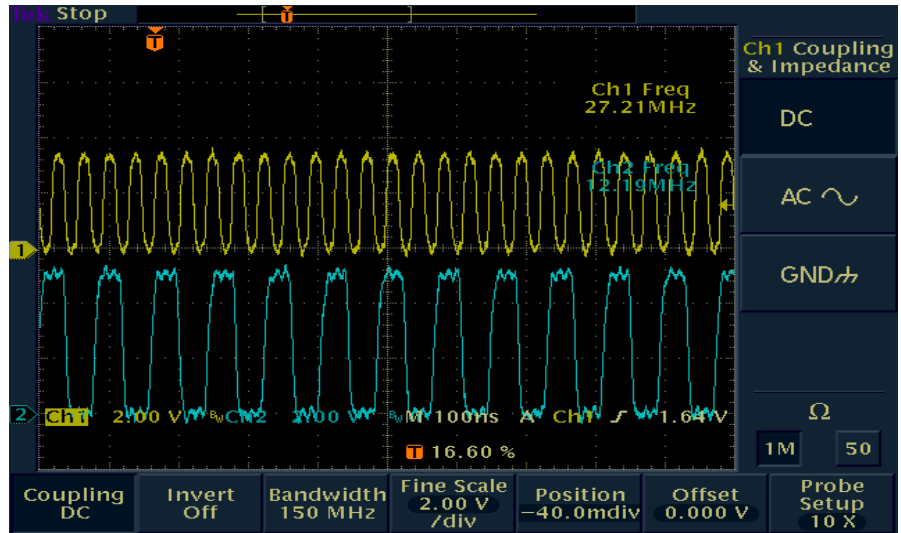

LRCLK -->  
 Check Point : U502 (18pin)  
 U501 (8pin)  
 BICK -->  
 Check Point : U502 (16pin)  
 U501 (6pin)

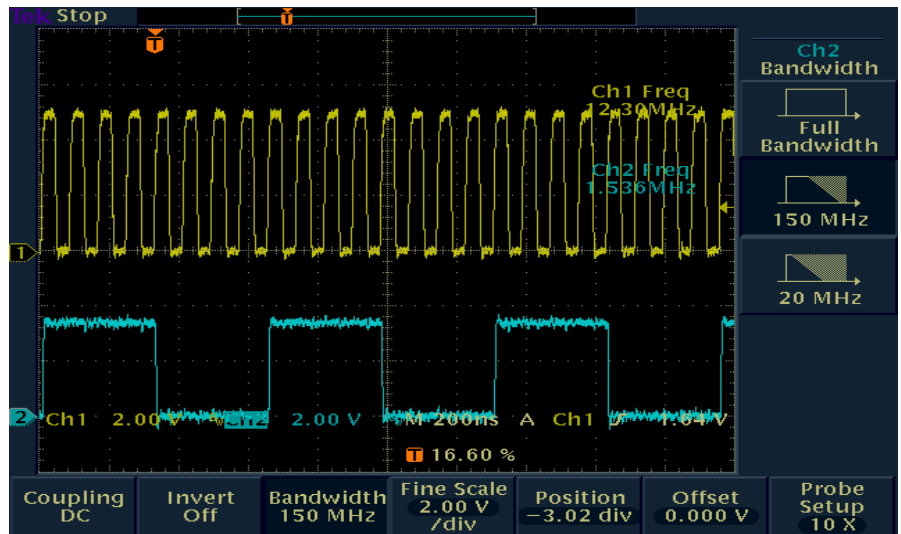

R\_AUDIO -->  
 Check Point : U502 (11pin),  
 U501 (18pin) By U601 (2Pin)  
 L\_AUDIO -->  
 Check Point : U502 (14pin),  
 U501 (19pin) By U601 (6pin)

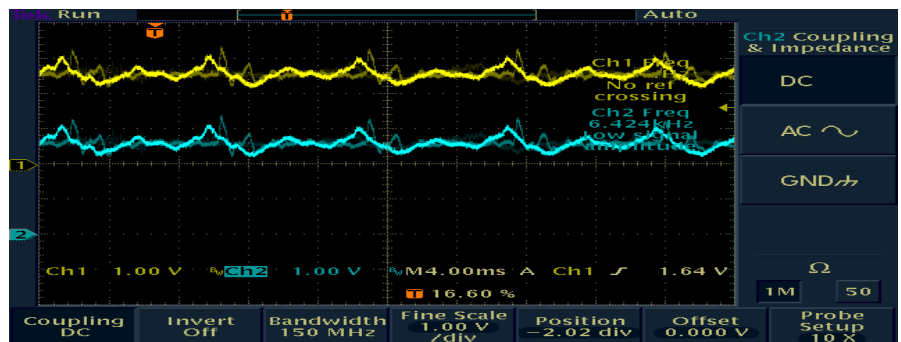

**Failure Causes and Solution**

If the Audio signal is no-output. must be Checking SYSCLK 27Mhz Of U501,U502 and VCC(5V) if you have to checking, If No problem. Check the install chip-position and short of solder, cold solder, etc.

Where are replace of component Part, Check the insertion of part

4-5. Channel Test

4-5-1. when “NO SIGNAL “ Message display.

1. U106(KA317 Ragrator)-> pin3 at 21V ~24V check  
R114 by 13(Vert) or 18(Horz) Voltage check

HOR (L)POLARITY -->  
Check Point : R121  
LNBA -->  
Check Point : R114, (18V)

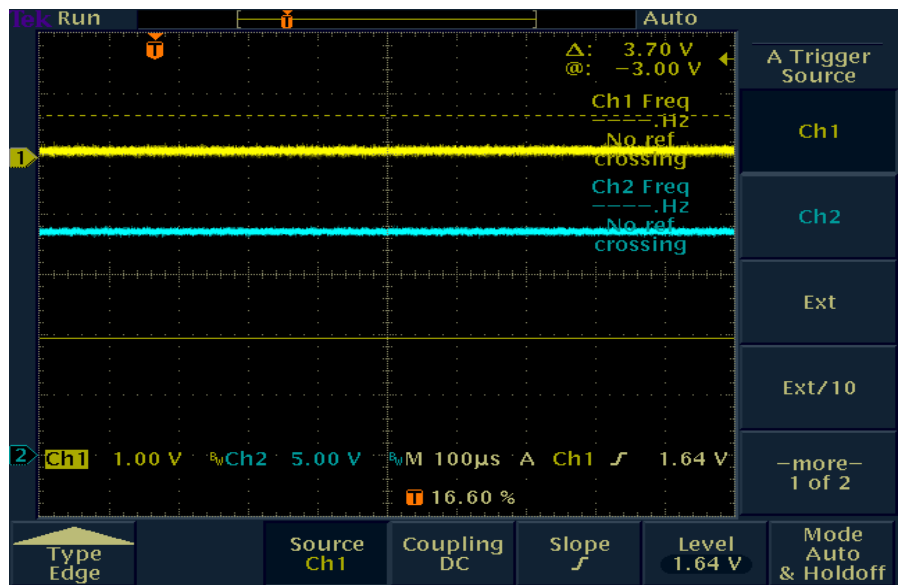

VERT (H)POLARITY -->  
Check Point : R121  
LNBA -->  
Check Point : R114, (13V)

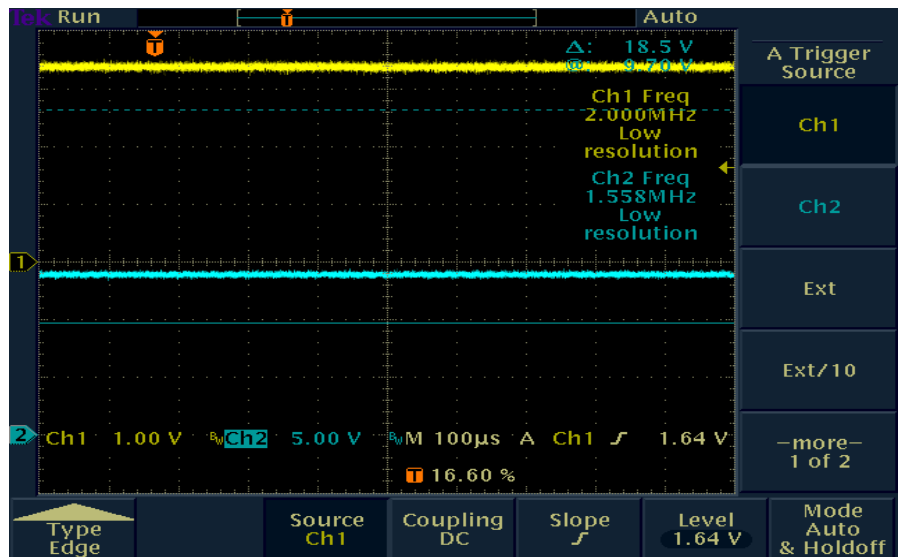

**Failure Causes and Solution**

If the 13(V)/18(H) Voltage is no-output. must be Checking High(3.3V)/low(0V) of R120(LNBP\_OFF) and if it high. Checking about Q107 ,U106(KA317), Q106 Part

Check the insertion of part and replace of component part

## 2. I2C Control Signal

SCL -->  
Check Point : R107  
U201(155pin),U204(6pin),  
U401(41pin),U501(11pin)  
R452.

SDA -->  
Check Point : R108  
U201(156pin),U204(5pin),  
U401(40pin),U501(12pin)  
R451.

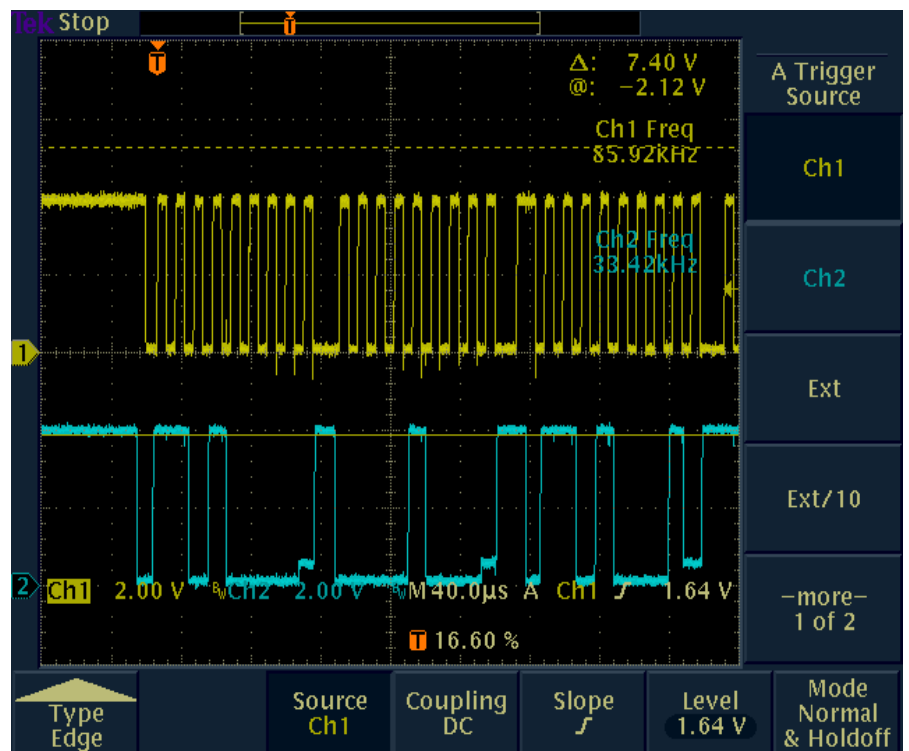

### ◆ Failure Causes and Solution

if Voltage is drop SCL as well as SDA. “ No Signal ” message will be Display at TV Screen.

therefore each of part check have to SCL with SDA of Voltage 3.2 ~3.5V.

Check the install chip-position and short of solder, cold solder, etc. Where are replace of component Part, Check the insertion of part

◆ 4-5-2. 22Khz Control through , BCLK and ERROROUT control signal

22Khz --→  
Check Point : R125

22Khz ON / OFF --→  
Check Point : R126

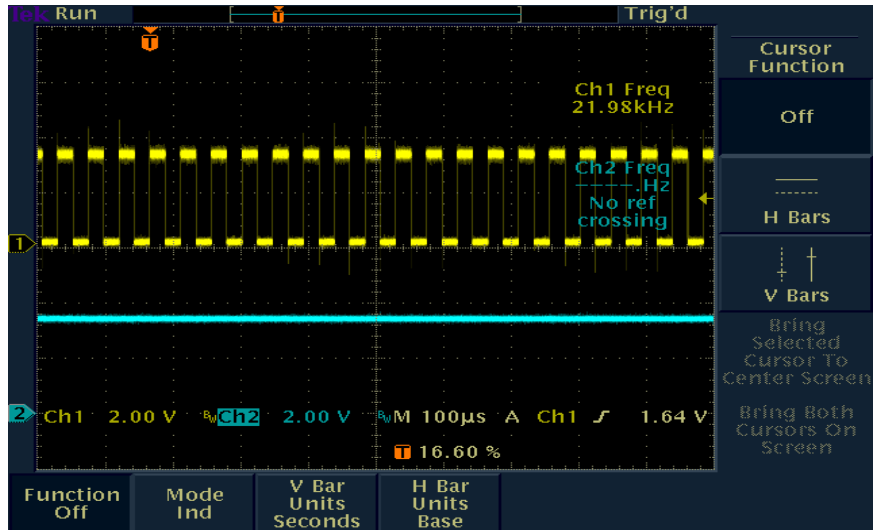

BCLK --→  
Check Point : R112

ERROROUT --→  
Check Point : R109

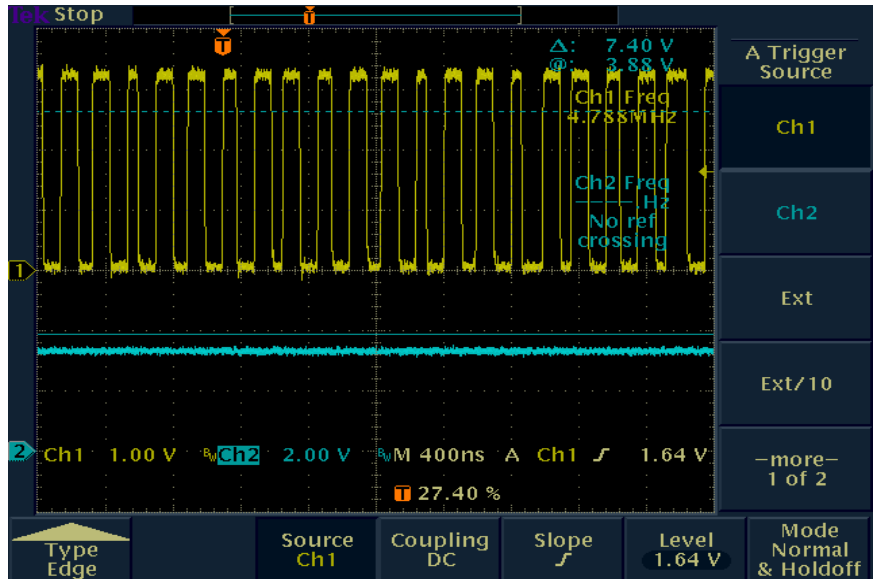

◆ Failure Causes and Solution

If the 22Khz with BCLK is no-output. Must be Voltage measurement supplied to Tunner  
Therefore be have to Checking Voltage BD102(30V), BD110&BD103(5V), BD105(3.3V)  
Check the install chip-position and short of solder, cold solder, etc.

# EM513S-IT201

## LOW COST FTA MODEL

K1,K2,K3 MOLD

NO DIGITAL AUDIO OUT PUT

NO S-VIDEO

**SMPS : SMPS-DDI180A / rev B**

**DATE :** 2001. 11.08

**VER :** M/P 1.2

**MODEL :** STRONG

**OPTION :** R/F MODUL,SAMSUNG TUNNER

**Etc :**

### 1. Strong MAN PCB ASS'Y

#### 1-1 SMD

Item	Type	Quantity	Reference	Part Number	Vendor	CORD	Remark
1	SMD	23	BD451,BD452,BD501,BD702,BD704 BD901,BD902,DB903,BD904,BD905 BD906,BD907,BD908,BD909,BD910 BD951,BD952,BD953,BD102,BD103 BD105,BD109,BD110,R114	FCM2012C-101	TAI-Tech	I3301-001375	FCM2012C-101 (2012 size)
1-1	SMD	1	R114	FCM2012C-470	TAI-Tech	I3301-001378	FCM2012C-470 (2012 size)
2	SMD	3	L201,L301,L401	FCI2012-100K	TAI-Tech	I2703-000125	10uH (2012 size)
3	SMD	4	L402,L403,L404,L405	FCI1608-1R8K	TAI-Tech	I2703-001896	1.8uH (1608 size)
4	SMD	77	CB101,CB103,CB104,CB105,CB106 CB107,CB201,CB202,CB203,CB204 CB205,CB206,CB207,CB208,CB209	CS1608Y5V104Z500NR	SAMWHA	I2203-006000	C-Ceramic, 0.1uF (1608 size)

			CB210, CB211, CB212, CB213, CB214				
			CB215, CB216, CB217, CB218, CB219				
			CB220, CB221, CB232, CB233, CB236				
			CB238, CB240, CB302, CB305, CB306				
			CB307, CB308, CB309, CB310, CB311				
			CB312, CB313, CB314, CB315, CB401				
			CB402, CB403, CB404, CB405, CB406				
			CB407, CB408, CB451, CB453, CB454				
			CB501, CB502, CB503, CB504, CB505				
			CB506, CB603, CB604, CB701, CB704				
			CB705, CB711, CB715, CB716, CB717				
			CB718, CB719, CB901, CB903, CB905				
			CB906, CB907				
5	SMD	3	CB102, CB904, CB452	CS2012Y5V104Z500NR	SAMWHA	I2203-000192	C-Ceramic, 0.1uF (2012 size)
6	SMD	6	C501, CB951, CB952, CB953, CB954, CB955	CS2012Y5V224Z500NR	SAMWHA	I2203-000563	C-Ceramic, 0.22uF (2012 size)
7	SMD	15	C107, C229, C237, C301, C304, C702, C703, C707, C708, C709, C710, C712, C713, C956, C957	CS1608X7R102K500NR	SAMWHA	I2203-000440	C-Ceramic, 1nF (1608 size)
8	SMD	7	C108, C235, C409, C412, C415, C418, C226	CS1608C0G220J500NR	SAMWHA	I2203-006001	C-Ceramic, 22pF (1608 size)
9	SMD	10	C222, C225, C227, C228, C230 C231, C238, C239, C240, C241	CS1608X7R103K500NR	SAMWHA	I2203-000257	C-Ceramic, 0.01uF (1608 size)
10	SMD	1	C223	CS1608Y5V105Z500NR	SAMWHA	I2203-040216	C-Ceramic, 1uF (1608 size)
11	SMD	1	C224	CS1608C0G510J500NR	SAMWHA	I2203-040217	C-Ceramic, 51pF (1608 size)
13	SMD	1	C234	CS1608X7R152K500NR	SAMWHA	I2203-005663	C-Ceramic, 1.5nF (1608 size)
14	SMD	1	C303	CS1608C0G200J500NR	SAMWHA	I2203-000548	C-Ceramic, 20pF (1608 size)
15	SMD	4	C410, C413, C416, C419	CS1608C0G680J500NR	SAMWHA	I2203-040223	C-Ceramic, 68pF (1608 size)
16	SMD	4	C411, C414, C417, C420	CS1608C0G331J500NR	SAMWHA	I2203-005661	C-Ceramic, 330pF (1608 size)
17	SMD	2	C601, C605	CS1608C0G470J500NR	SAMWHA	I2203-005000	C-Ceramic, 47pF (1608 size)

18	SMD	2	C602,C606	CS1608C0G391J500NR	SAMWHA	I2203-002017	C-Ceramic, 390pF (1608 size)
19	SMD	2	C706,C714	CS1608C0G100J500NR	SAMWHA	I2203-000296	C-Ceramic, 10pF (1608 size)
20	SMD	1	R116	CR 1/10 241 JT	HAN RYUK	I2007-040210	240ohm (2012 size)
21	SMD	4	R117,R118,R129,R130	CR 1/10 472 JT	HAN RYUK	I2007-000872	4.7Kohm (2012 size)
22	SMD	1	R119	CR 1/10 122 JT	HAN RYUK	I2007-000221	1.2Kohm (2012 size)
23	SMD	6	R709,R711,R715,R718,R719, R738	CR 1/10 620 JT	HAN RYUK	I2007-001100	62ohm (2012 size)
24	SMD	1	R135	CR 1/10 102 JT	HAN RYUK	I2007-000468	1Kohm (2012 size)
25	SMD	2	R763,R768	CR 1/10 202 JT	HAN RYUK	I2007-000671	2Kohm (2012 size)
26	SMD	1	R122	CR 1/10 911 JT	HAN RYUK	I2007-001239	910ohm (2012 size)
27	SMD	2	R127,R901	CR 1/10 121 JT	HAN RYUK	I2007-000023	120ohm (2012 size)
28	SMD	1	BD701	CR1/10 152 JT	HAN RYUK	I2007-000241	1.5Kohm (2012 size)
29	SMD	1	BD703	CR1/10 332 JT	HAN RYUK	I2007-000686	3.3kohm (2012 size)
30	SMD	3	RA206,RA207,RA210	CN 164 330 JT	HAN RYUK	I2011-001282	33ohm
31	SMD	2	RA201,RA202	CN 164 102 JT	HAN RYUK	I2011-001279	1Kohm
32	SMD	5	RA203,RA204,RA205,RA208,RA209	CN 164 472 JT	HAN RYUK	I2011-001280	4.7Kohm
33	SMD	6	RA301,RA302,RA303,RA101,RA102 RA103	CN 164 101 JT	HAN RYUK	I2011-001281	100ohm
34	SMD	25	R104,R106,R115,R120,R121 R125,R126,R128,R131,R132 R243,R453,R455,R605,R607 R707,R708,R713,R714,R742 R746,R751,R755,R766,R767	CR 1/16 103 JT	HAN RYUK	I2007-000090	10Kohm (1608 size)
35	SMD	19	R216,R225,R229,R230,R235 R236,R237,R301,R306,R454 R743,R744,R748,R749,R750 R752,R753,R754,R781	CR 1/16 472 JT	HAN RYUK	I2007-000084	4.7Kohm (1608 size)
36	SMD	9	R207,R209,R210,R401,R402 R451,R452,R501,R502	CR 1/16 330 JT	HAN RYUK	I2007-000113	33ohm (1608 size)
37	SMD	11	R112,R133,R143,R146,R204	CR 1/16 000 JT	HAN RYUK	I2007-000070	0ohm (1608 size)

			R232,R234,R238,,R239,R245					
			R780					
38	SMD	3	R148,R603,R610	CR 1/16 473 JT	HAN RYUK	I2007-000939	47Kohm	(1608 size)
39	SMD	19	R140,R206,R224,R227,R606	CR 1/16 102 JT	HAN RYUK	I2007-000078	1Kohm	(1608 size)
			R608,R710,R712,R717,R720					
			R740,R747,R764,R770,R771					
			R723,R760,R761,R762					
40	SMD	1	R141	CR 1/16 153JT	HAN RYUK	I2007-000092	15Kohm	(1608 size)
41	SMD	2	R105,R211	CR 1/16 621 JT	HAN RYUK	I2007-001093	620ohm	(1608 size)
42	SMD	1	R212	CR 1/16 622 FT	HAN RYUK	I2007-040209	6.2K(F)ohm	(1608 size)
43	SMD	1	R213	CR 1/16 1692 FT	HAN RYUK	I2007-007893	16.9K 1%ohm	(1608 size)
44	SMD	2	R222,R223	CR 1/16 332 JT	HAN RYUK	I2007-000082	3.3Kohm	(1608 size)
45	SMD	1	R226	CR 1/16 100 JT	HAN RYUK	I2007-000309	10ohm	(1608 size)
46	SMD	2	R252,R253	CR 1/16 105JT	HAN RYUK	I2007-000109	1Mohm	(1608 size)
47	SMD	1	R302	CR 1/16 151 JT	HAN RYUK	I2007-000402	150ohm	(1608 size)
48	SMD	2	R303,R305	CR 1/16 180 JT	HAN RYUK	I2007-000463	18ohm	(1608 size)
49	SMD	1	R304	CR 1/16 201 JT	HAN RYUK	I2007-000539	200ohm	(1608 size)
50	SMD	1	R307	CR 1/16 270 JT	HAN RYUK	I2007-000659	27ohm	(1608 size)
51	SMD	5	R403,R404,R406,R408,R410	CR 1/16 750 FT	HAN RYUK	I2007-001164	75 1%ohm	(1608 size)
52	SMD	1	R503	CR 1/16 512 JT	HAN RYUK	I2007-040211	5.1Kohm	(1608 size)
53	SMD	1	R504	CR 1/16 4R7 JT	HAN RYUK	I2007-000882	4.7ohm	(1608 size)
54	SMD	2	R601,R612	CR 1/16 683 JT	HAN RYUK	I2007-000100	68Kohm	(1608 size)
55	SMD	2	R602,R609	CR 1/16 333 JT	HAN RYUK	I2007-000134	33Kohm	(1608 size)
56	SMD	8	R705,R706,R721,R722,R726,	CR 1/16 221 JT	HAN RYUK	I2007-000075	220ohm	(1608 size)
			R727,R730,R731					
57	SMD	16	R724,R725,R728,R729,R732,	CR 1/16 223 JT	HAN RYUK	I2007-000094	22Kohm	(1608 size)
			R733,R734,R739,R756,R757,					
			R758,R759,R772,R773,R774,					
			R778					
58	SMD	3	R735,R736,R737	CR 1/16 682 JT	HAN RYUK	I2007-000087	6.8Kohm	(1608 size)

59	SMD	3	R775,R776,R777	CR 1/16 113 JT	HAN RYUK	I2007-000329	11Kohm (1608 size)
60	SMD	2	R741,R779	CR 1/16 822 JT	HAN RYUK	I2007-000089	8.2Kohm (1608 size)
61	SMD	1	R745	CR 1/16 302 JT	HAN RYUK	I2007-000083	3Kohm (1608 size)
62	SMD	3	R765,R214,R215	CR 1/16 470 JT	HAN RYUK	I2007-000072	47ohm (1608 size)
63	SMD	5	R769,R109,R107,R108,R138	CR 1/16 101 JT	HAN RYUK	I2007-000074	100ohm (1608 size)
64	SMD	2	R144,R145	CR 1/16 1R0 JT	HAN RYUK	I2007-002425	1ohm (1608 size)
65	SMD	4	R405,R407,R409,R411	CR 1/16 132 FT	HAN RYUK	I2007-000231	1.3K 1%ohm (1608 size)
66	SMD	21	Q104,Q107,Q108,Q109,Q110, Q111,Q113,Q114,Q452,Q703, Q704,Q708,Q709,Q710,Q712, Q713,Q715,Q716,Q717,Q718, Q719	KST3904-MTF(SOT-23)	KEC	I0501-002275	SOT-23
67	SMD	7	Q701,Q702,Q705,Q706,Q707, Q720,Q721	MMBT2222A(SOT-23)	KEC	I0501-002283	SOT-23
68	SMD	1	U103	AMS1117CD-3.3V	AMS	I1203-001921	AMS1117CD-3.3V
69	SMD	1	Q711	KN3906S(SOT-23)	KEC	I0501-002276	SOT-23
70	SMD	1	U105	74HC04(SOP)	Fairchild	I0801-002385	74HC04(SOP)
71	SMD	1	U201	L64108E(PQFP)	LSI logic	I0902-001285	L64108E
72	SMD	1	U202	TE28F800C3TA90	INTEL	I1107-001163	TE28F800C3TA90
73	SMD	1	U203	KM416V1204CJ-6	samsung	I1105-001299	KM416V1204CJ-6
74	SMD	1	U204	AT24C64N-10SC-2.7	ATMEL	IMD13-00125D	AT24C64N-10SC-2.7
75	SMD	1	U206	DS1819	Dallas	I1203-001932	DS1819 3.3V(Vcc)
76	SMD	1	U301	L64005	LSI logic	I1204-001621	L64005
77	SMD	1	U302	KM416S1020BT-G/F10	samsung	I1105-001300	KM416S1020BT-G/F10
78	SMD	1	U401	BT864AKPF(PQFP)	Rockwell	I1204-001610	BT864AKPF
79	SMD	1	U502	PCM1723E(24SSOP)	borbrow	I1002-001180	Or U501에 AK4363
80	SMD	1	U601	KA358D(SOP)	Fairchild	I1201-000166	KA358
81	SMD	2	U701,U702	CD74HC4053M(SOP)	PHILIP	I0801-003010	CD74HC4053M(SOP)
82	SMD	1	U951	SP232ECN(SOP)	SIPEX	I1006-000002	SP232ECN
83	Ass'y	1	SMPS	DDI-180/A rev B	Dongdo	SMPS-DDI180B	

84		1	MAINPCB	IT513SS-MAIN ,ver. M/P 1.0, 2001.09.21		P-IT513-R1.3	SAMSUNG TUNER applied
----	--	---	---------	--	--	--------------	-----------------------

### 1-2 자수삽

Item	구분	Quantity	Reference	Part Number	Vendor	CORD	Remark
1		1	CE106	1uF/50V-5*11*5,FORMING CUT TYPE	DAEWOO	I2401-000602	C-AL ; 1uF/50V-5*11*5,FORMING CUT TYPE
2	DIP	1	CE401	47uF/25V-5*11*5	DAEWOO	I2401-001075	C-AL ; 47uF/25V-5*11*5, FORMING CUT TYPE
3	DIP	5	CE102,CE904,CE905,CE452,CE453	47UF/50V	DAEWOO	I2401-003510	C-AL ; 47uF/50V-6.3*11*5, FORMING CUT TYPE
4	DIP	3	CE704,CE906,CE907	100uF, 20%, 25V, GP, TP, 6X11, 5	DAEWOO	I2401-002347	C-AL ; 100uF, 20%, 25V, GP, TP, 6X11, 5
5	DIP	36	CE202,CE203,CE204,CE205,CE206	10uF/25V-5*7*5	DAEWOO	I2401-001077	C-AL ; 10uF/25V-5*7*5, FORMING CUT TYPE
			CE301,CE451,CE501,CE502,CE503				
			CE601,CE602,CE603,CE604,CE701				
			CE702,CE703,CE708,CE711,CE712				
			CE713,CE714,CE715,CE716,CE717				
			CE718,CE719,CE720,CE721,CE723				
			CE724,CE730,CE731,CE732,CE733				
			CE951				
6	DIP	6	CE101,CE103,CE104,CE105,CE901	330uF, 20%, 16V, GP, TP, 8X11.5, 5	DAEWOO	I2401-001100	C-AL ; 330uF, 20%, 16V, GP, TP, 8X11.5, 5
			CE903				
7	DIP	1	D101	1N4004A	PHILIP, ROHM	I0402-001242	Diode
8	DIP	1	D901	MTZ J 33B	PHILIP, ROHM	I0403-001406	30V ZENER DIODE
9	DIP	1	D103	MTZ J 3.6B	PHILIP, ROHM	I0403-001407	3V ZENER DIODE
10	DIP	4	Q103,Q106,Q112,Q116,Q451	KTA1273(TO92)	KEC	I0502-001107	TO-92
			Q714				
10-1	DIP	2	Q106,Q112	KSB772-Y	Fairchild	I0502-000249	TR-POWER,KSB772-Y,PNP,10W,TO-126
11	DIP	1	CON201	SW 0500-12	HAN LIM	IAJ37-00605G	2.0mm, 12-Pin Wafer
12	DIP	1	CON701	2203-42ST (-A- Type)	ILSSAN	I3722-001410	ILSSAN:DUAL SCART 2203-42T
13	DIP	1	CON702	JS0401315N		I3722-001211	PHONO RCA JACK-4PACK
14	DIP	1	CON901	5267-11		I3711-005000	5267-11
15	DIP	1	CON951	3302-09S-AFS-0	ILSSAN	I3710-001563	DB9
16	DIP	2	JP451,JP452	PLUG-CONNECTOR ; 2250-10P-DS-T	ILSSAN	I3711-005001	

17	DIP	1	TU101	TBMU30311IMP(SAMSUNG)	Samsung	i4703-000002	
18	DIP	2	U102,U451	KA7805TU	Fairchild	I1203-001922	대체 품 : KA7805; 누워서 작업할것
19	DIP	1	U205	VCXO27M	Kony	I2806-001223	OSCILLATOR-VCXO ; 13T-63AP,27MHz-3.3V
20	DIP	1	SWRST	KPT1115	KYUNGIN	I3403-001097	SW PUSHBUTTON
21	DIP	1	U106	KA317TU(TO220)	Fairchild	I1203-001923	LM317
22	DIP	1	H1(FOR U106)	002A-1		I6203-000002	HEAT SINK 27mm(w) * 40mm(L)
23	DIP	1	H1 SCREW(FOR U106)	TT2, BIN(+)*WTH 3*6 (BLACK) T		I6009-001019	SCREW
24		1	CABLE-POWER ; KkJ640	CABLE-POWER ; KkJ640		I3801-000001	
25		1	Shielding Foam Gasket	Shielding Foam Gasket	ESONG	I6302-000001	10mm(W)*10mm(H) * 15mm(L)tunner top at attach

## 2. IT513S FRONT ASS'Y(K1 PCB)-EF513S-IT101

Auto/ Hand Insertion			NEW FRONT				
Item	Type	Quantity	Reference	Part Number	Vendor	CORD	Remark
1	DIP	1	U3B	HI-M602H3-2		I1204-001623	(supporter) , (U3A)TSOP1238
2	DIP	2	R1,R9	RNL 1/6 331 JT-52	HAN RYUK	I2001-040213	330ohm
3	DIP	3	R6,R7,R8	RNL 1/6 102 JT-52	HAN RYUK	I2001-003113	1K
4	DIP	1	R5	RNL 1/6 330 JT-52	HAN RYUK	I2001-003115	33
5	DIP	3	Q1,Q2,Q3	2N3904(TO92)	KEC	I0501-002277	TO-92
6	DIP	1	CE1	47uF/25V-5*11*5	DAEWOO	I2401-001075	C-AL ; 47uF/25V-5*11*5, FORMING CUT TYPE
7	DIP	1	CB1	CR051BX7R104Z500R	SAMWHA	I2202-000857	C-CERAMIC, MLC-RADIAL ; 100nF, 10%, 50V,X7R
8	DIP	1	CON2	2.0mm pitch, 130mm,12pin	Molex	I3711-001146	2.0mm, 12-Pin Cable Ass'y
9	DIP	7	S1,S2,S3,S4,S5,S6,S7	KPT1115	KYUNGIN	I3403-001097	SW PUSHBUTTON
10	DIP	1	LED1	LH3330	LIGITEK	I0601-001378	LED ; ROUND ; LH3330,RED,5mm,565mm
11	DIP	1	LED2	LG3330	LIGITEK	I0601-001377	LED ; ROUND ; LG3330,GREEN,5mm,565mm

12	DIP	2	LED support	support hight : 7mm	ya young	I6103-001040	LED support
13	DIP	12	JP1~JP10,JP12,JP13	7.5mm, JUMPER		I3811-000548	7.5mm, JUMPER
14		1	FRONT PCB(IT513S)	IT513S-K1; P/P VER 1.2 2001.05.09		P-IT513F-1.2	

### 3. IT513S RF\_SUB ASS'Y

M\_code : ES513S-IT002  
M\_code name : PCB SUB ASS ' Y ; 512, SATELLITE, SAMSUNG, VER R1.0

PART LIST VER : IT513\_S SUB ver:R1.0

#### Auto/hand insertio

Item	Type	Quantity	Reference	Part Number	Vendor	CORD	Remark
1		1	RF_SUB PCB	IT612_R1.3 VER 1.3, 1Layer		PSIT513-R1.2	1
2		1	U16	RMUP74055WT	SAMSUNG	IRMUP74055WT	1
3	DIP	2	JP7,JP10			I3710-001567	2

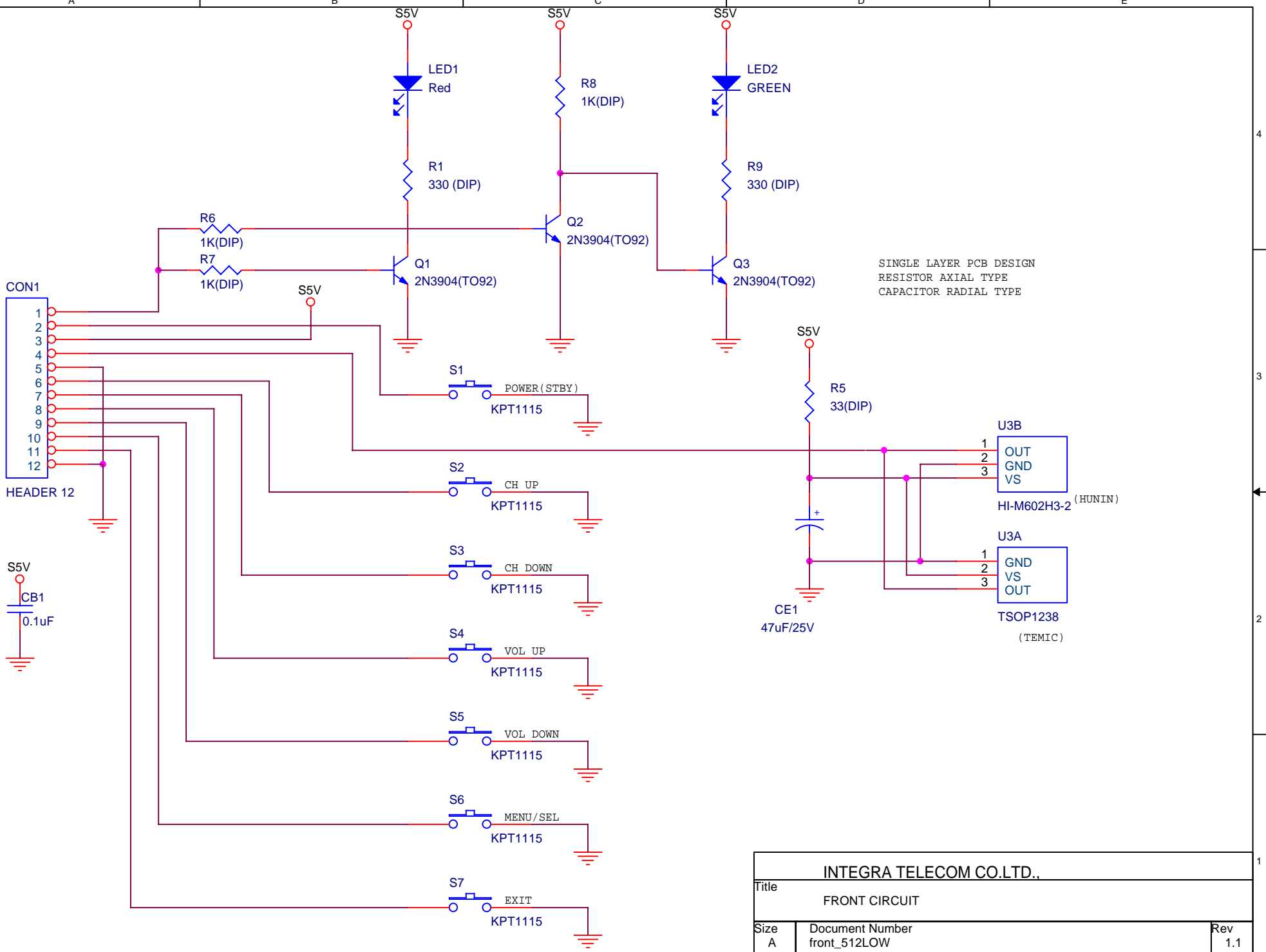

SINGLE LAYER PCB DESIGN  
 RESISTOR AXIAL TYPE  
 CAPACITOR RADIAL TYPE

INTEGRA TELECOM CO.LTD.,		
Title FRONT CIRCUIT		
Size A	Document Number front_512LOW	Rev 1.1
Date: Friday, November 02, 2001	Sheet 1	of 1

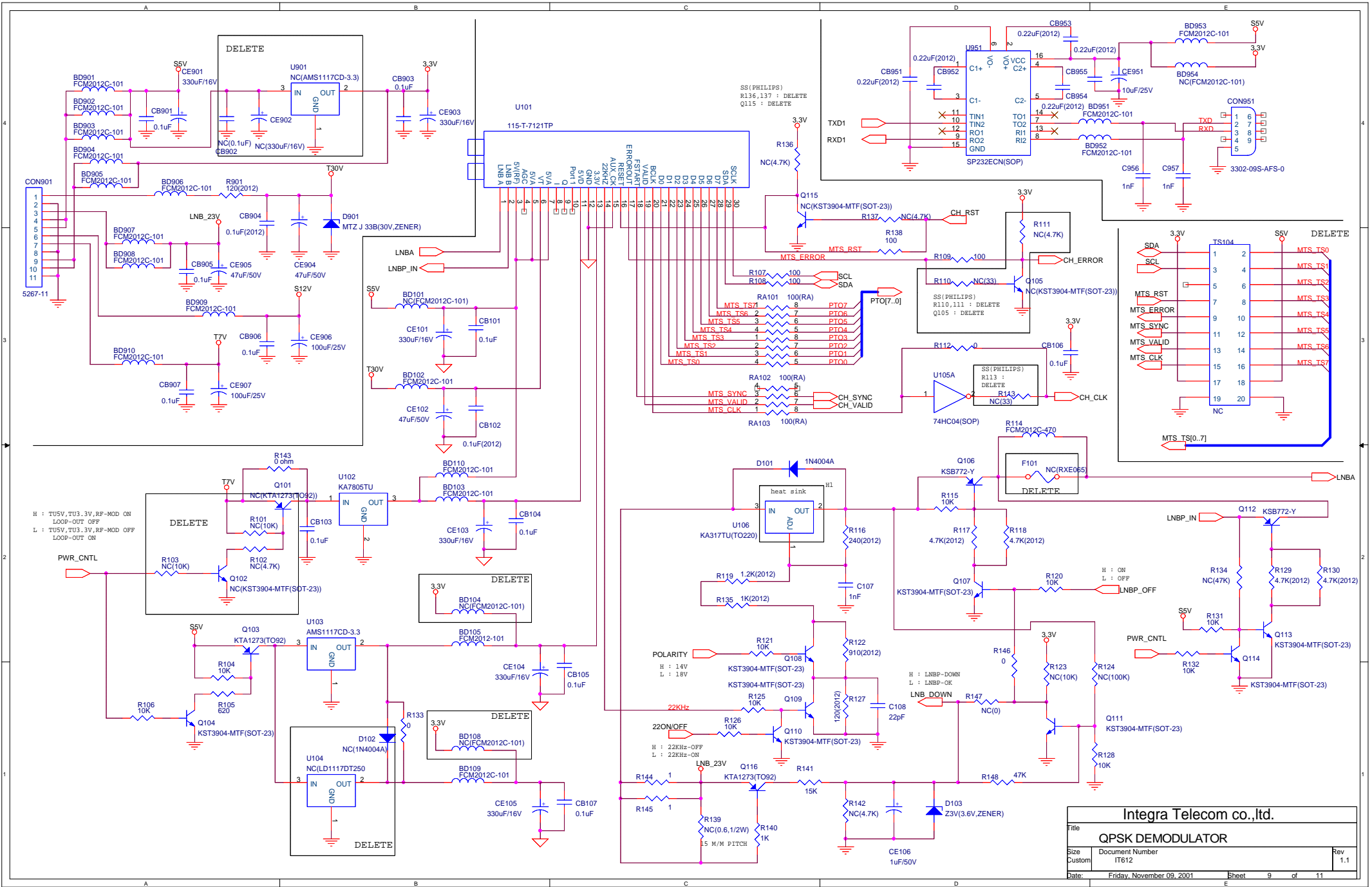

Integra Telecom co.,ltd.		
Title QPSK DEMODULATOR		
Size Custom	Document Number IT612	Rev 1.1
Date: Friday, November 09, 2001	Esheet 9	of 11

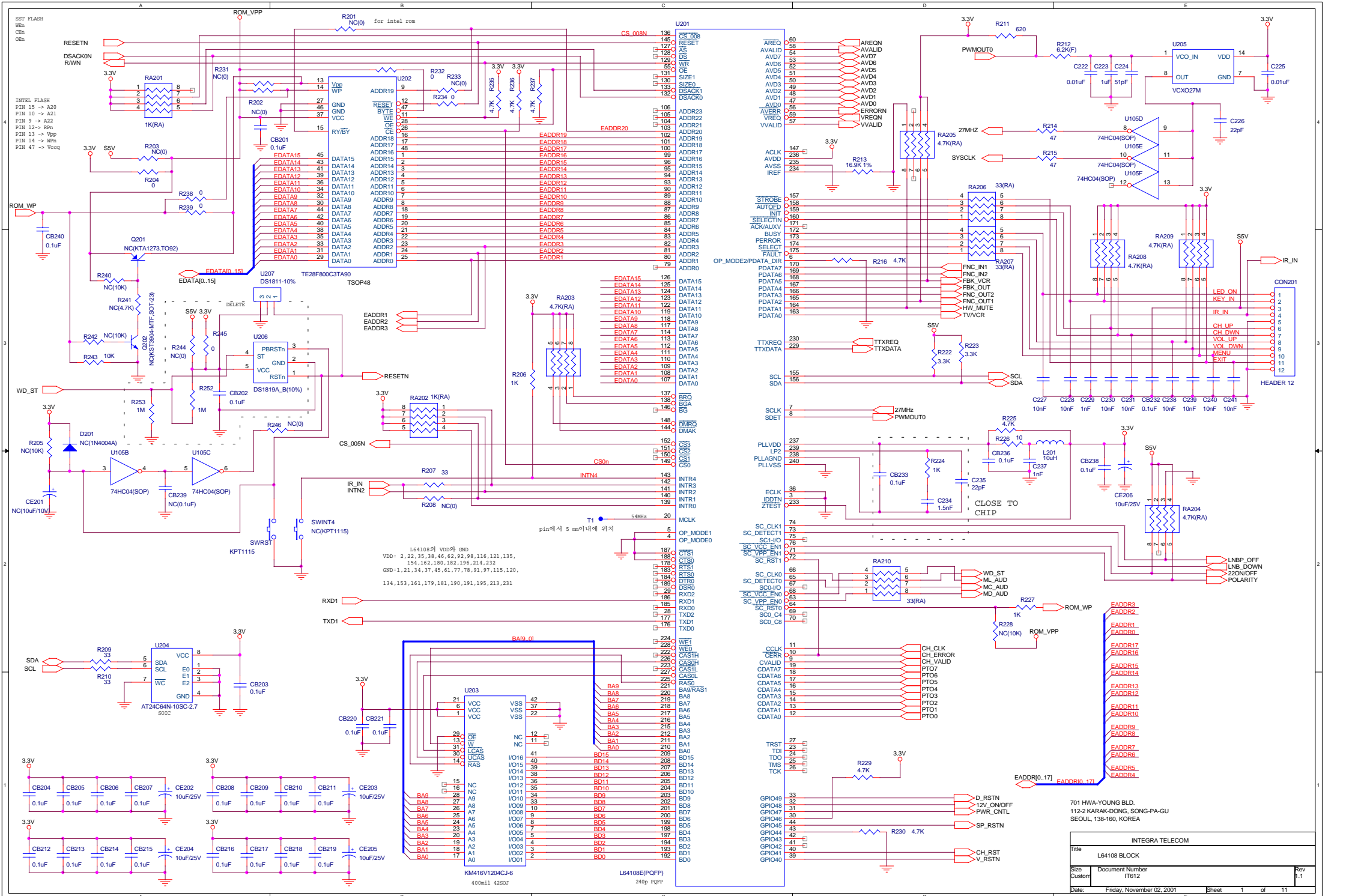

L64108의 VDD와 GND  
 VDD: 2, 22, 35, 38, 46, 62, 92, 98, 116, 121, 135,  
 154, 162, 180, 182, 196, 214, 232  
 GND: 1, 21, 34, 37, 45, 61, 77, 78, 91, 97, 115, 120,  
 134, 153, 161, 179, 181, 190, 191, 195, 213, 231

INTEGRA TELECOM		
Title L64108 BLOCK		
Size Custom	Document Number IT612	Rev 1.1
Date: Friday, November 02, 2001	Sheet 1 of 11	



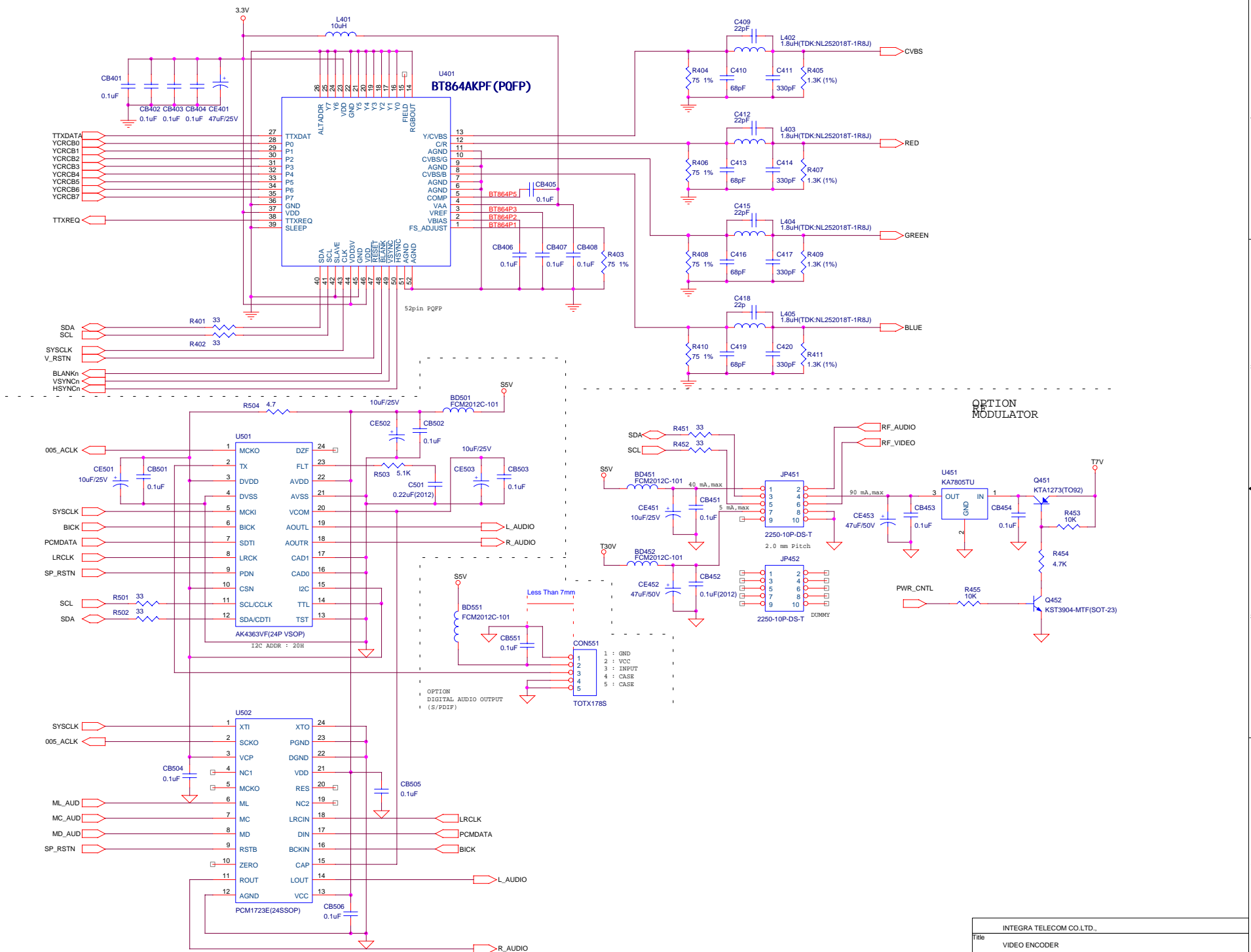

INTEGRA TELECOM CO.LTD.,			
Title	VIDEO ENCODER		
Size	Document Number	Rev	
Customer	T612	1.1	
Date:	Friday, November 02, 2001	Sheet	5 of 11

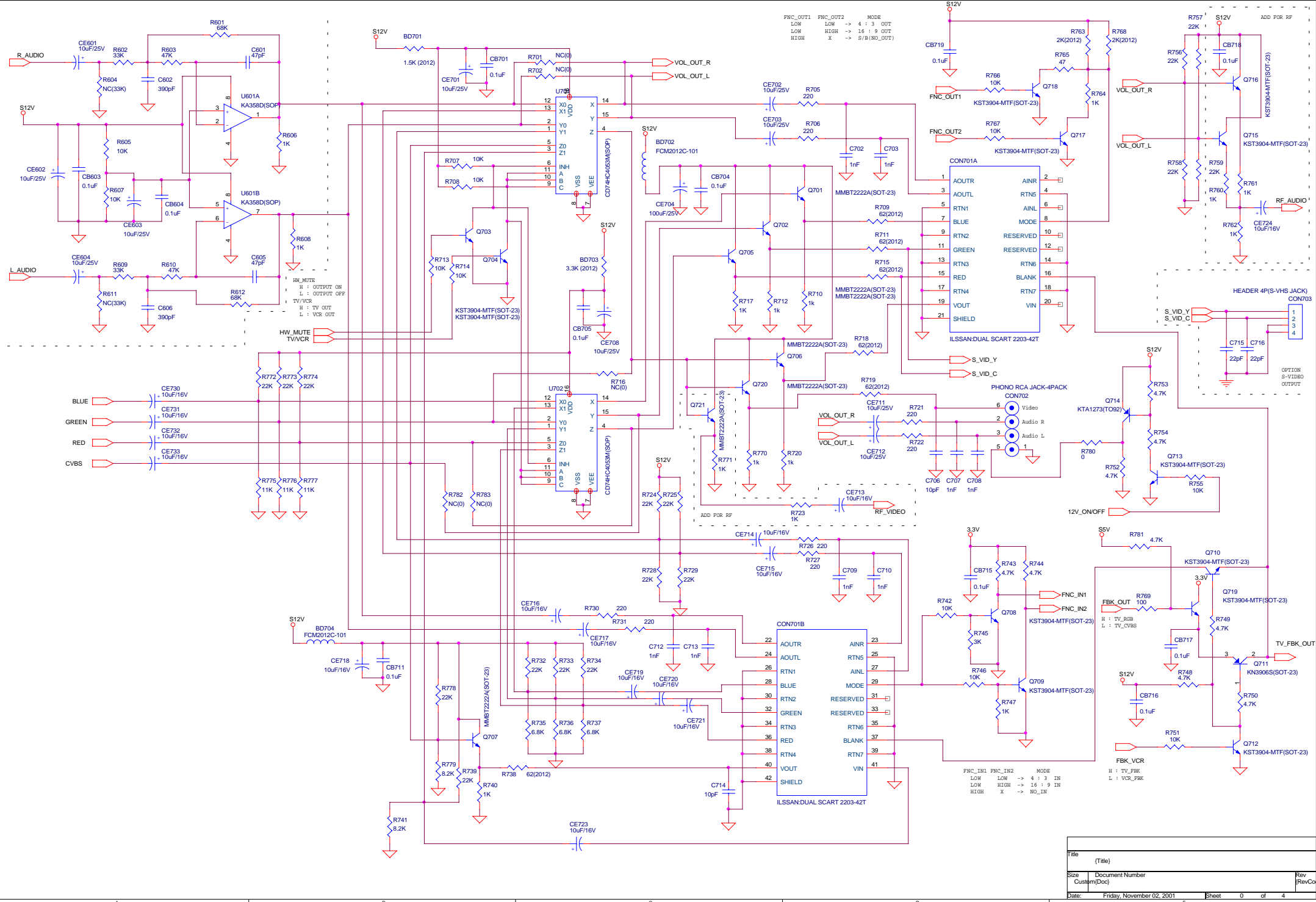

FNC\_OUT1 FNC\_OUT2 MODE  
 LOW LOW -> 4 : 3 OUT  
 HIGH HIGH -> 16 : 9 OUT  
 HIGH X -> S/B(NO\_OUT)

FNC\_IN1 FNC\_IN2 MODE  
 LOW LOW -> 4 : 3 IN  
 LOW HIGH -> 16 : 9 IN  
 HIGH X -> NO\_IN

INH\_MUTE  
 H : OUTPUT ON  
 L : OUTPUT OFF  
 TV/VCR  
 H : TV OUT  
 L : VCR OUT

OPTION S-VIDEO OUTPUT

Title	(Title)	Rev	(Rev/Code)
Size	Document Number		
	Custom(Doc)		
Date:	Friday, November 02, 2001	Sheet	0 of 4

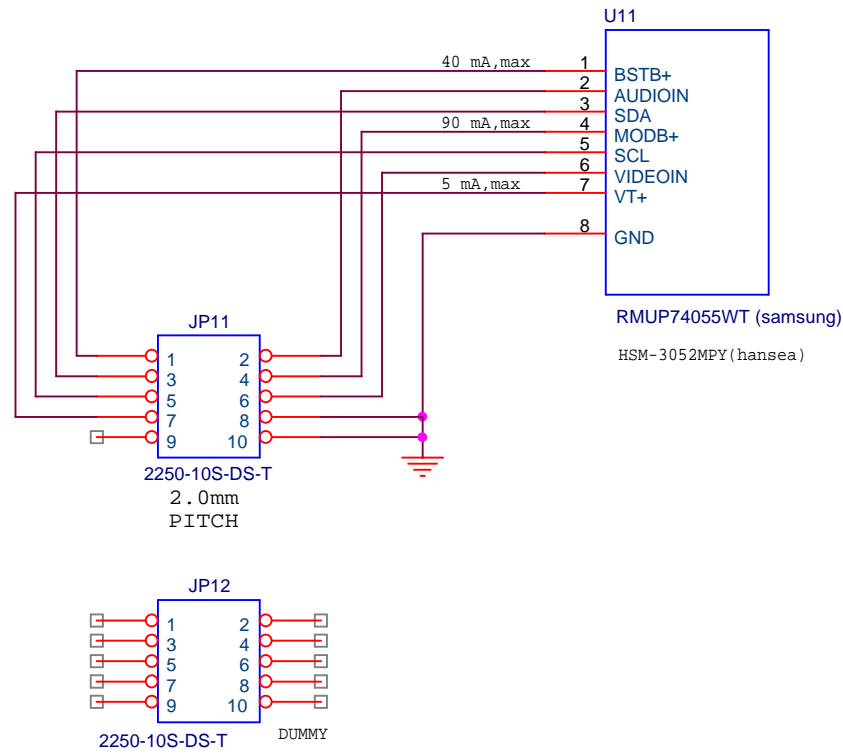

Title		
RF MODULATOR SUB PCB		
Size	Document Number	Rev
A	ITF	1.0
Date:	Friday, September 21, 2001	Sheet 0 of 8

v-cut

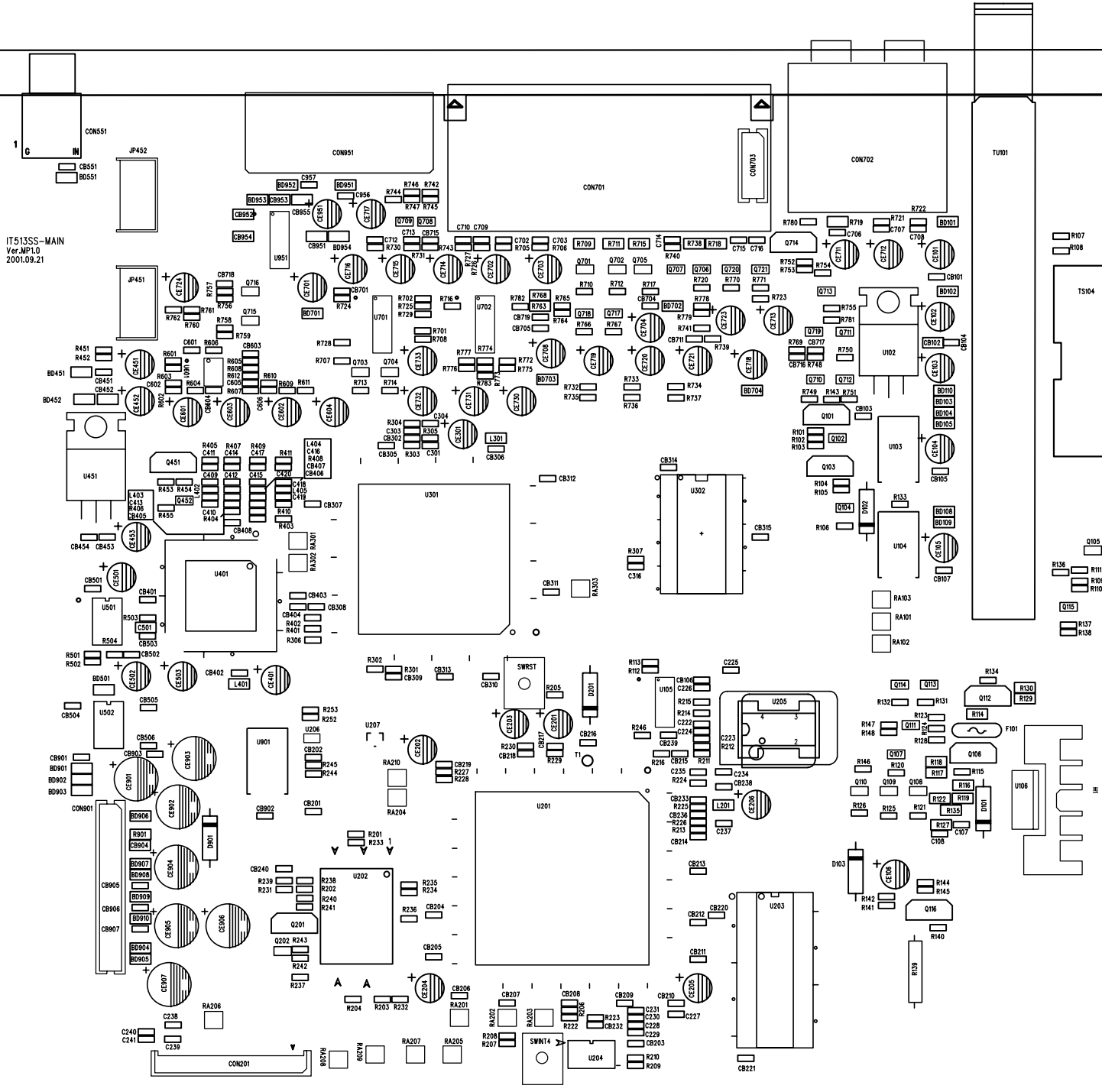

IT513SS-MAIN  
Ver.MPL0  
2001.09.21

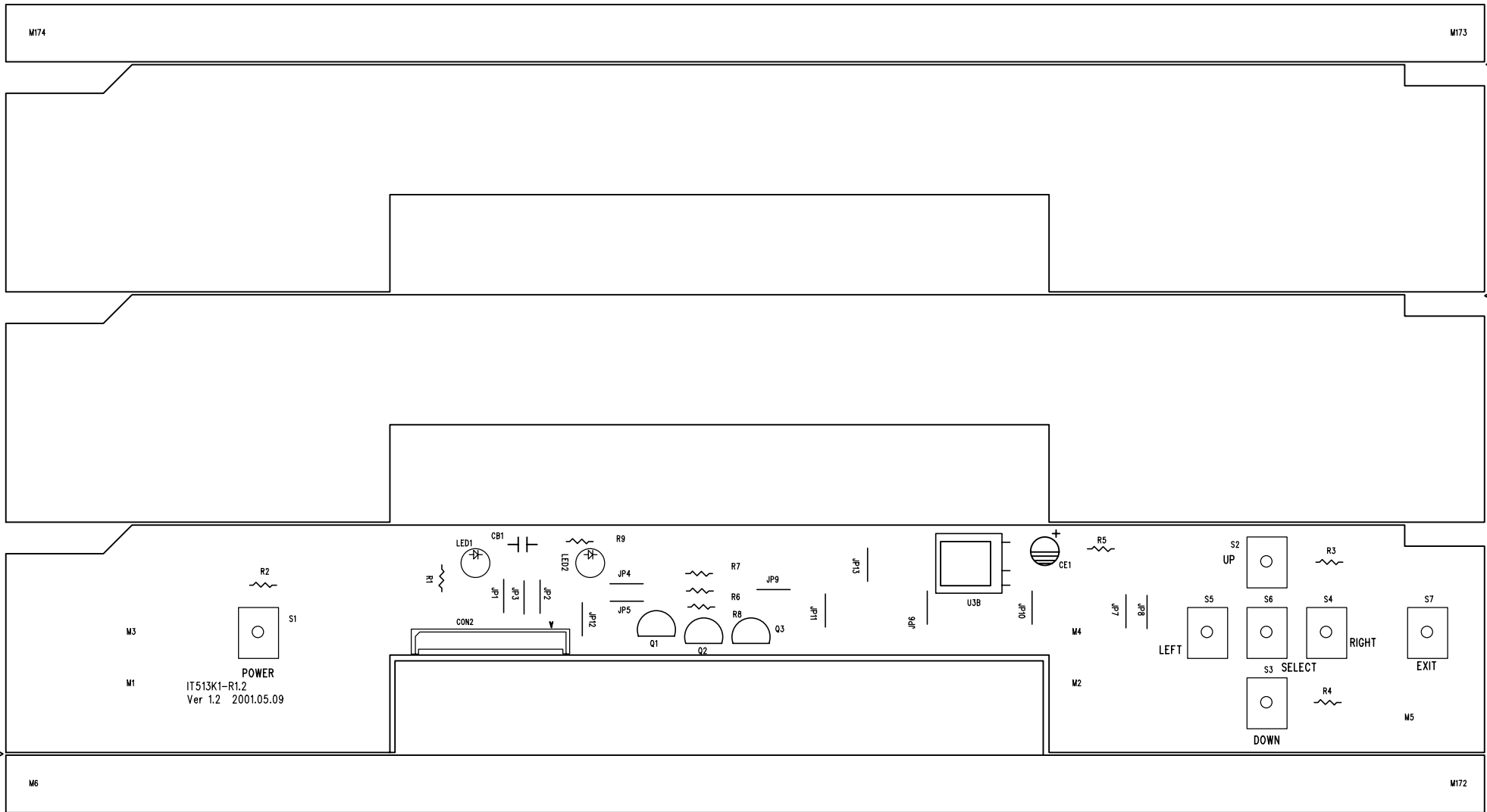

258 x 141.1 mm

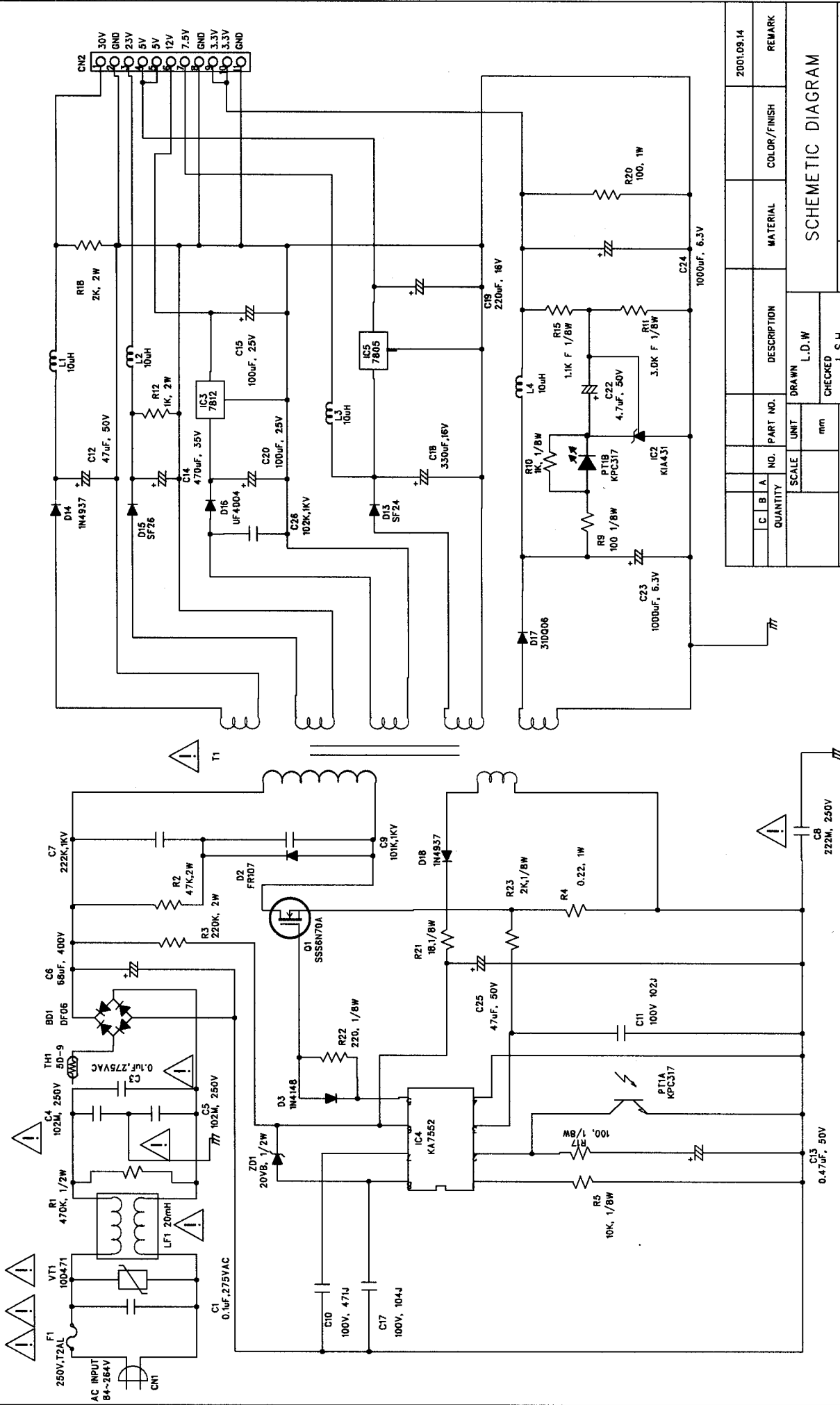

QUANTITY		SCALE		UNIT		PART NO.		DESCRIPTION		MATERIAL		COLOR/FINISH		REMARK	
C	B	A													
Dong Do						ELECTRONICS CO., LTD		DRAWN		L.D.W		CHECKED		L.S.H	
								APPROVED		P.S.H					
SCHEMATIC DIAGRAM															
DDI-180/A(Rev.B)															

QUANTITY		SCALE		UNIT		PART NO.		DESCRIPTION		MATERIAL		COLOR/FINISH		REMARK	
C	B	A													
Dong Do						ELECTRONICS CO., LTD		DRAWN		L.D.W		CHECKED		L.S.H	
								APPROVED		P.S.H					
SCHEMATIC DIAGRAM															
DDI-180/A(Rev.B)															

2001.09.14

ISSUE

CAUTION

FOR CONTINUED  
PROTECTION AGAINST  
FIRE HAZARD, REPLACE  
ONLY WITH SAME  
TYPE FUSE

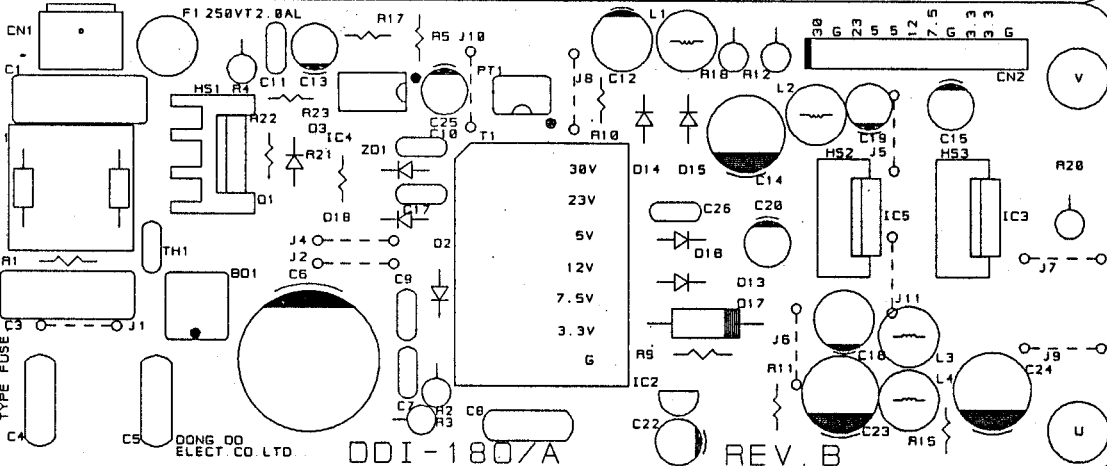

DOONG DO  
ELECT CO LTD

DDI-1807A

REV. B

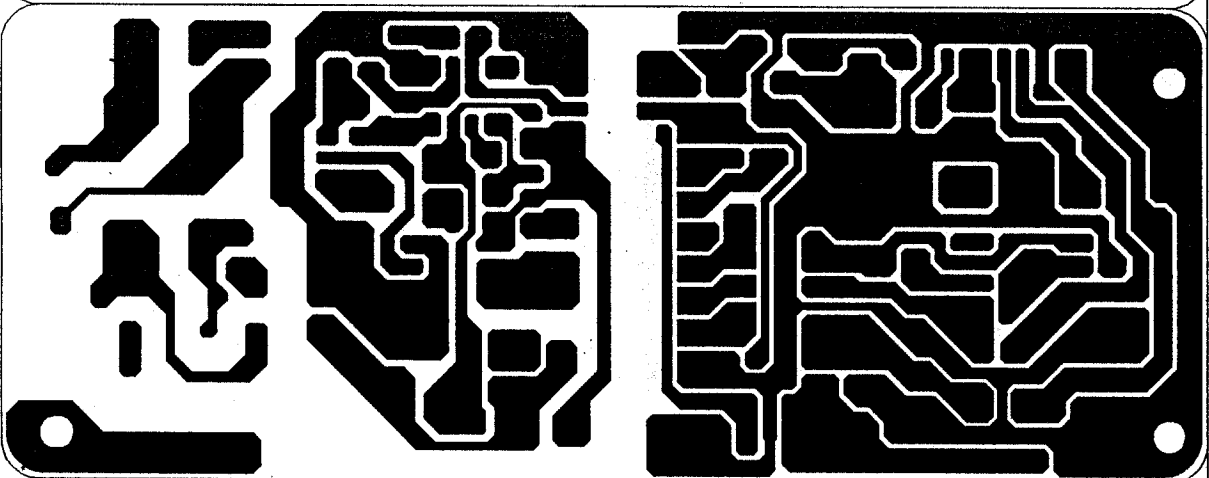
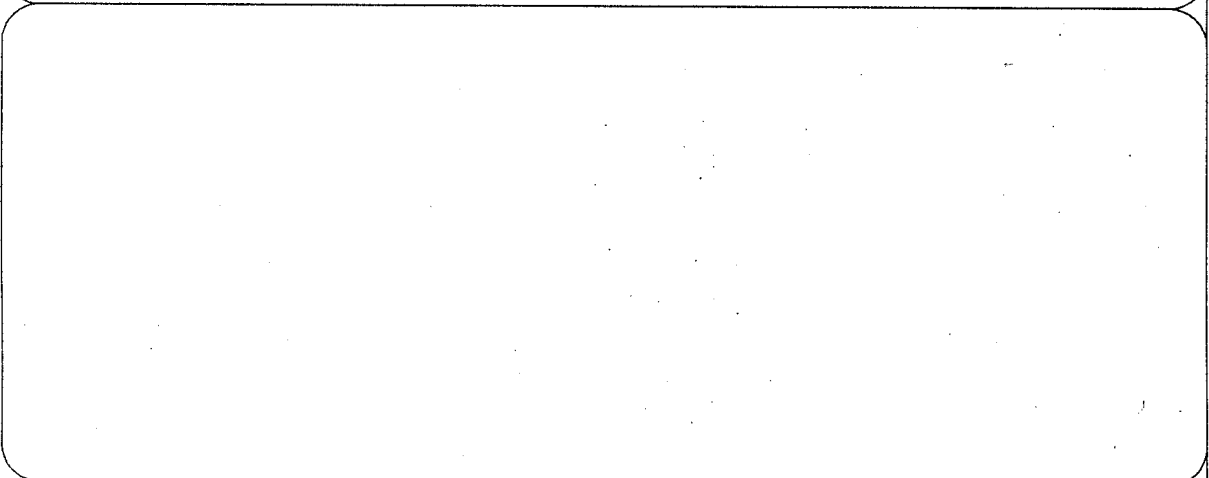
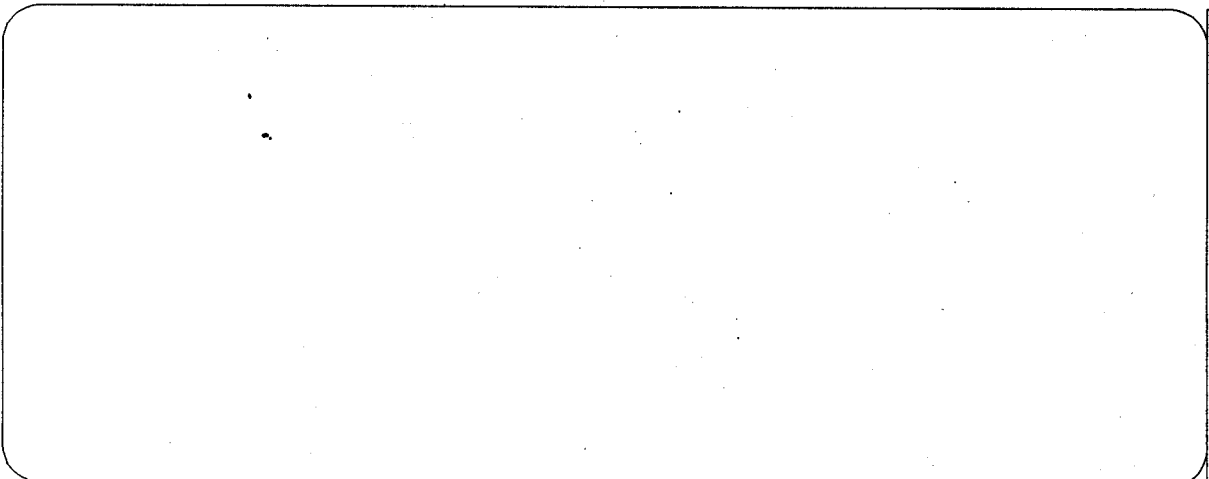

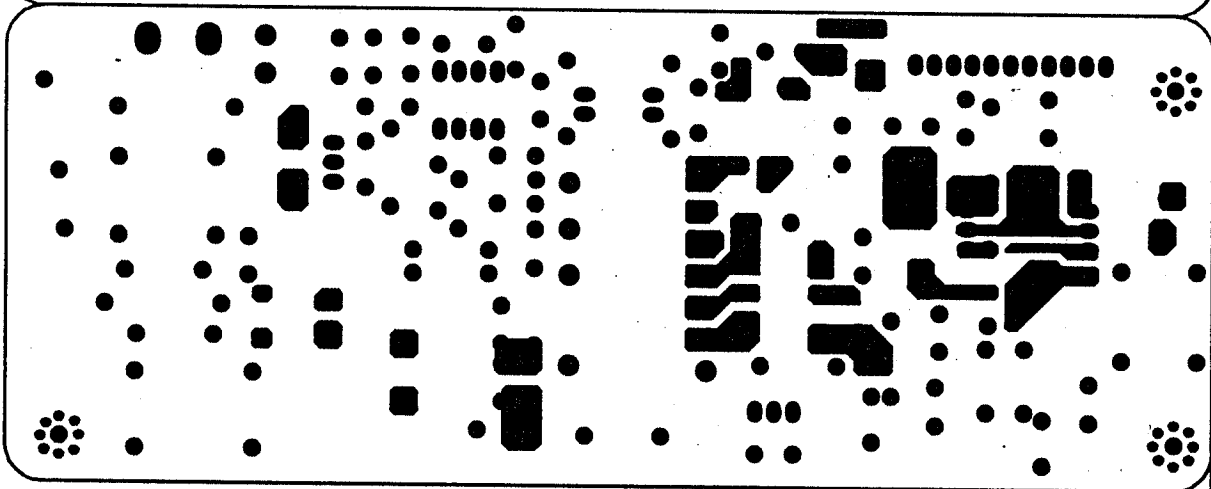

## PROGRAM DOWNLOAD

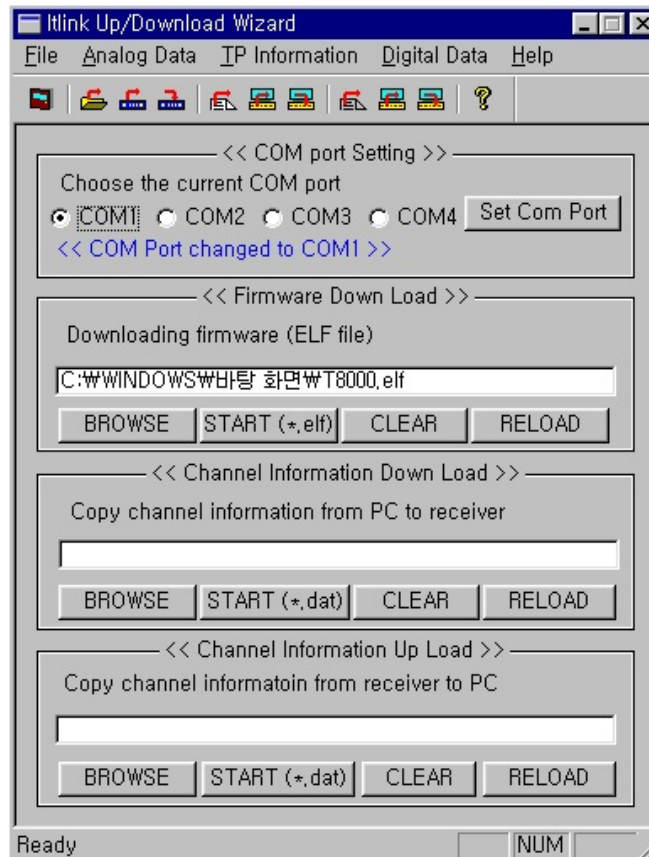

### Firmware Download

You can download firmware to receiver.

- Press "BROWE" button to select firmware(ELF) to downloading.
- After selecting firmware, you can start downloading by pressing "START" button.
- You can see progressing bar while downloading.
- The receiver will automatically restart when downloading is finished.

### Channel Information upload

You can save channel information of receiver to PC file by using this function

- You have to select a file to save in PC by pressing "BROWSE" button.
- Press "START" button to start uploading.

### Channel Information download

You can download channel information saved above to receiver.

- You have to select a file to download to receiver by pressing "BROWSE" button.
- Press " START" button to start downloading.

## SYSTEM UPGRADE

If there is a new version of software available for your receiver, you are able to download it automatically via the satellite signal of ASTRA19.2 East.

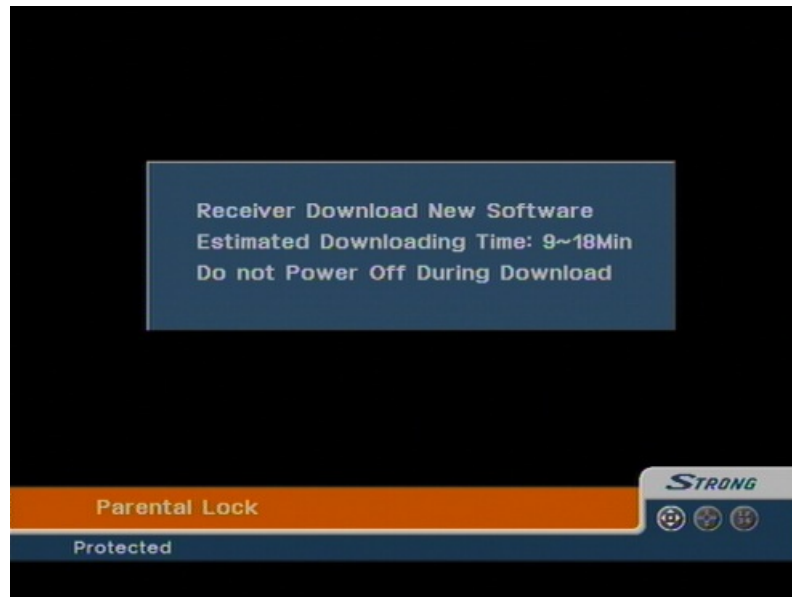

1. Please wait while your receiver is checking if your software version is the newest one available.
2. If you already have the newest version nothing will happen, and you can leave the menu.  
When you need the newest version software, the receiver will automatically download that version from the satellite signal. After the download is finished, your screen will turn green for a few seconds while the receiver is re-booting.  
When the screen is back is to normal, you can leave the menu.



### Tips

Do not turn off your receiver while you are downloading new software.  
Be sure that your receiver is connected to the satellite signal of ASTRA19.2 East.